



## Programmable Meter for Analog Sensors/Transducers



- Supply Voltage: 24 V  $\pm$  20 %
- Temperature Range: 0 to 70 C
- Interface:
  - ✓ 0 to 10 V or 4 to 20 mA with over-voltage protection
- Resolution:
  - ✓ 16-bit analog to digital converter
- Update Rate:
  - ✓ 67 milliseconds
- Digital Outputs:
  - ✓ TDRO10A0 No Digital Output
  - ✓ TDRO10A1 Four programmable PNP outputs, 100 mA per output maximum
  - ✓ TDRO10A2 Two Programmable PNP outputs, 100 mA per output maximum
- Analog Output:
  - ✓ TDRO10A2 One 16-bit voltage output, 0 to 10 V, 100% adjustable
- Display:
  - ✓ Six-digit LED (five-digit usable for analog display), 0.56 inches, 6-millisecond refresh rate
- Programming Capability:
  - ✓ Zero and Span are 100% adjustable
  - ✓ Number of digits displayed and decimal point
  - ✓ Programmable switch-point for each digital output
  - ✓ Analog output is 100% adjustable
- Compact 1/8 DIN housing, panel mountable

## **INDEX**

TO PROGRAM GENERAL PARAMETERS FOR ANALOG METER	3
TO PROGRAM DIGITAL OUTPUT SETPOINTS	6
TO PROGRAM ANALOG OUTPUT (RE-TRANSMISSION) SETPOINTS	8
TROUBLESHOOTING THE ANALOG METER	11
SETTING THE JUMPERS FOR VOLTAGE OR CURRENT OUTPUT	12
POWER AND I/O CONNECTOR PINOUT	12
PANEL CUTOUT	13
METER INSTALLATION	13
METER DIMENSTIONS	13
OPTIONAL ACCESSORIES	14

## TO PROGRAM GENERAL PARAMETERS FOR ANALOG METER:

1. Press the “PROG.” and “↑” buttons at the same time.
2. The meter will read “CAL” (Calibrate); press “↑” to select “Yes,” and press “Prog.” to continue. (To cancel: press “↓” to select “No,” and press “Prog.”)

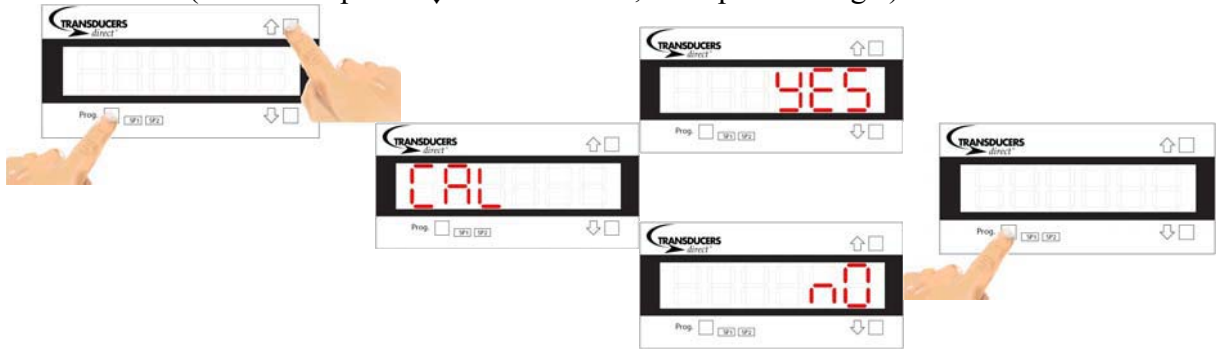

3. Next, the meter will alternate between “CAL IN” and “CAL OU” (Calibrate Input & Calibrate Output, respectively (CAL OU” only with the Analog output model)). At this point the input calibration (“CAL IN”) will be discussed. The analog output calibration section discusses the “CAL OU” function. Press “↑” to select “CAL IN,” and press “Prog.” to continue.

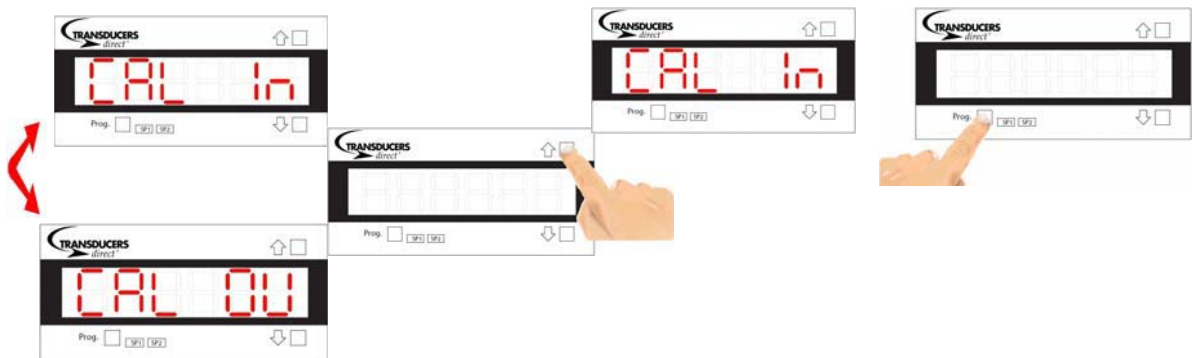

4. The meter will alternate between “DEC PT” (decimal point) and a number showing the current location of the decimal point
  - a. Press “PROG.” to skip changing the decimal point
  - b. Press “↑” or “↓” to move the decimal point up or down; when finished, press and hold “PROG.” for one second to end.

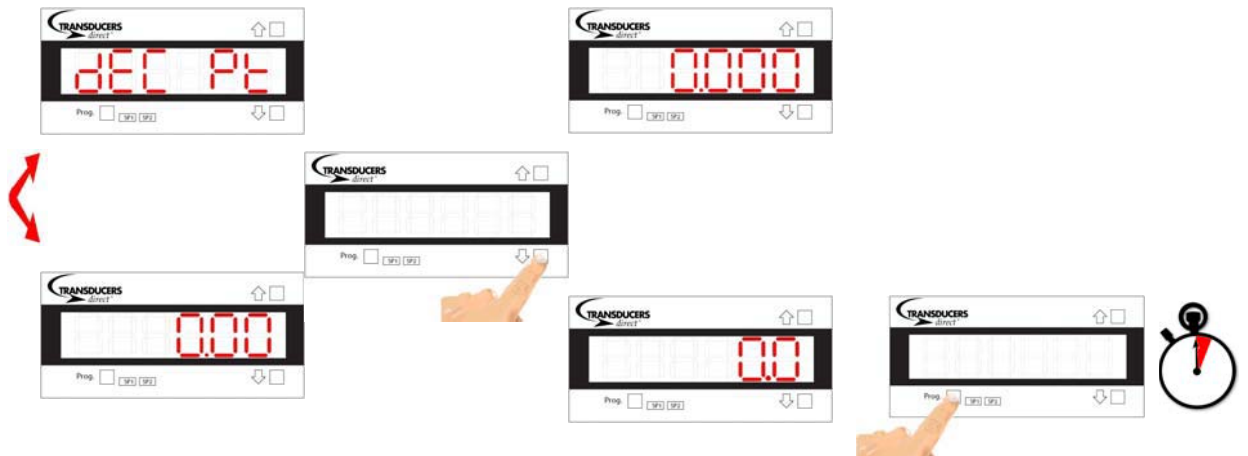

5. The meter will then alternate between “P ADJ” and the value of the potentiometer set point
  - a. Press “PROG.” to skip changing the P adj value
  - b. Press “↑” or “↓” to change the P adj point
    - i. Set the P adj value to the value in k $\Omega$  of the attached potentiometer
    - ii. Press “PROG.” quickly to advance to the next digit
    - iii. If you are using a voltage input, or a 4-20 ma input set this value to “0.000”
    - iv. When finished, press and hold “PROG.” for one second to end

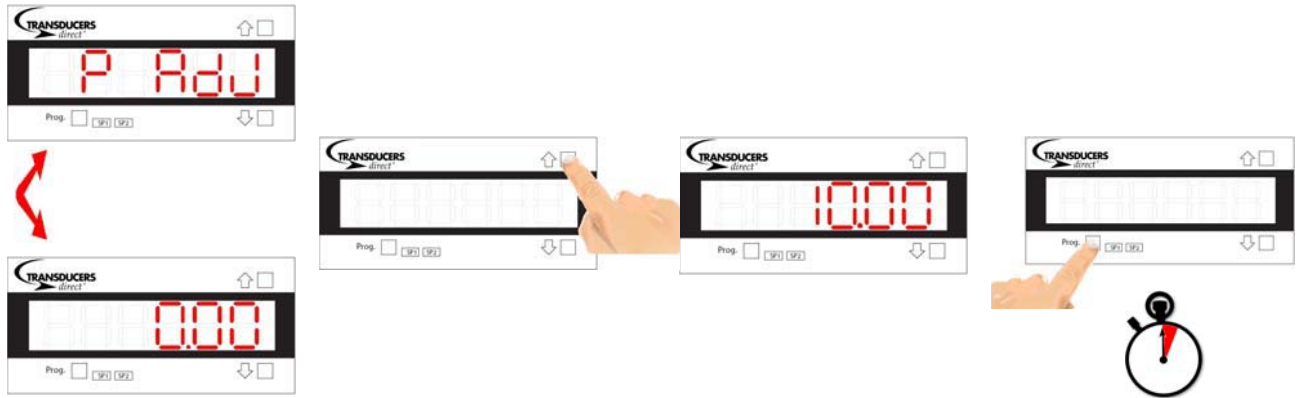

6. The meter will alternate between “ZERO” and the value of the zero point
  - a. Press “PROG.” to skip changing the zero point
  - b. Press “↑” or “↓” to change the zero point
    - i. Move the transducer to the desired zero position
    - ii. Press “↑” or “↓” to increase or decrease each digit
    - iii. Press “PROG.” quickly to program the next digit
    - iv. When finished, press and hold “PROG.” for one second to end

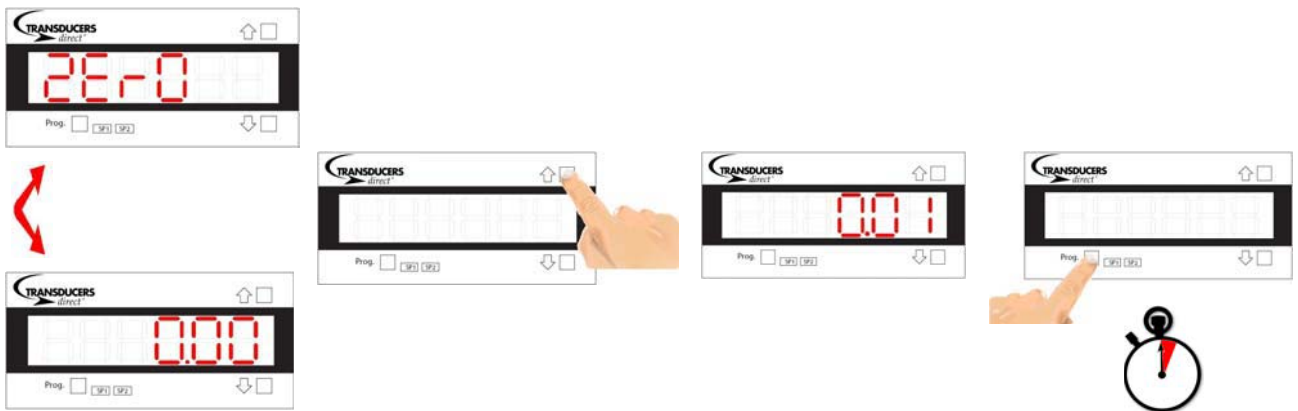

7. The meter will alternate between “SPAN” and the value of the span point
  - a. Press “PROG.” to skip changing the span point
  - b. Press “↑” or “↓” to change the span point
    - i. Move the transducer to the desired span position
    - ii. Press “↑” or “↓” to increase or decrease each digit
    - iii. Press “PROG.” quickly to program the next digit
    - iv. When finished, press and hold “PROG.” for one second to end

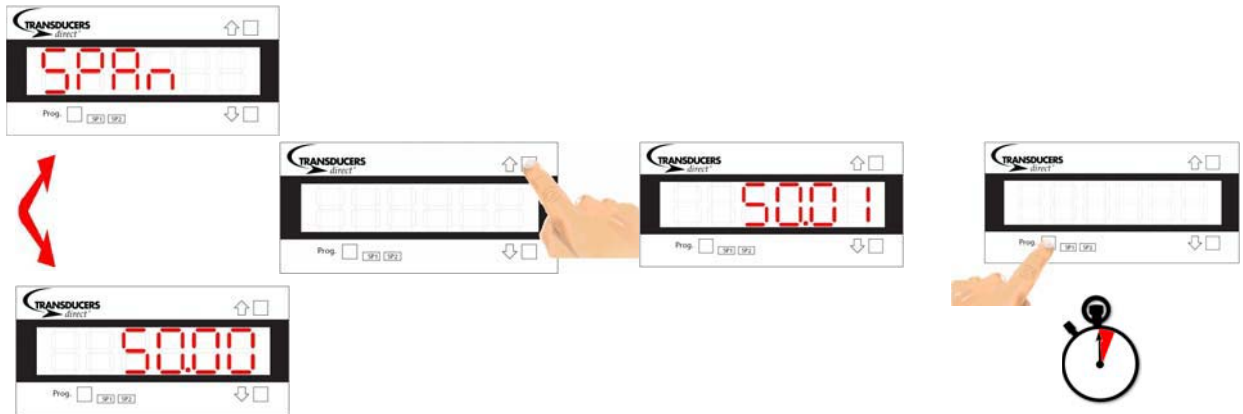

## TO PROGRAM DIGITAL OUTPUT SETPOINTS:

1. Press the “PROG.” and “↓” buttons at the same time.
2. The meter will alternate between “SETPT1” and the current set-point
  - a. Press “PROG.” to skip to the next digit; press “↑” or “↓” to change the value of that digit.
  - b. When finished, press and hold “PROG.” for one second to end.

The illustration below shows how to accept the current value (25.00 in this example)



3. Press “PROG.” to move to the next set-point (“SETPT2”). The meter will alternate between “SETPT2” and the current set-point (30.00 in this example)
  - a. Press “PROG.” to skip to the next digit; press “↑” or “↓” to change the value of that digit.
  - b. When finished, press and hold “PROG.” for one second to end.

The illustration on the next page shows the exact sequence of changing digital output 2 (“SETPT2”) from 30.00 to 40.00.

- Notice that pressing the “Prog.” button changes which digit flashes on and off.
- This flashing digit is the “selected digit” (similar to a cursor in a word processor).
- To change its value, simply press either the “↑” or “↓” button.
- To go to the next digit simply tap the “Prog.” Button.
- When the desired value has been entered, Press and hold the “Prog.” Button.
- When the actual position is above the “SETPT1” position, the digital output 1 will activate and the “SP1” LED will illuminate (Similarly with “SETPT2” and “SP2” LED).

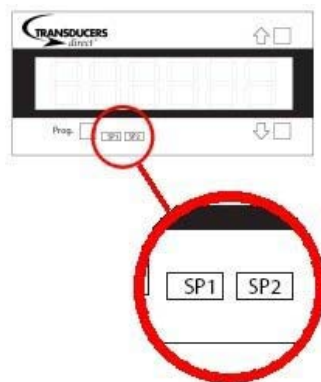

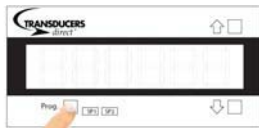
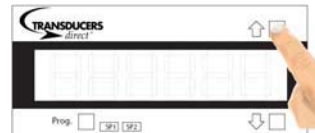
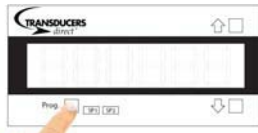
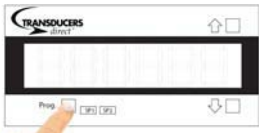
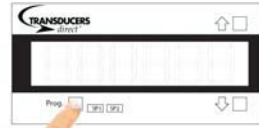
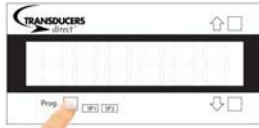

## TO PROGRAM ANALOG OUTPUT (RE-TRANSMISSION) SETPOINTS:

The analog output is a fully scalable linear output that can be programmed in units of position vs. current or voltage, dependant upon the jumper setting on the rear of the unit. (see “setting the jumpers for voltage or current output” section). The illustration to the right shows an example where the desired output is 4 mA at 50mm and 20 mA at 150mm. Notice that when the position reaches 100mm the current output will be 12 mA.

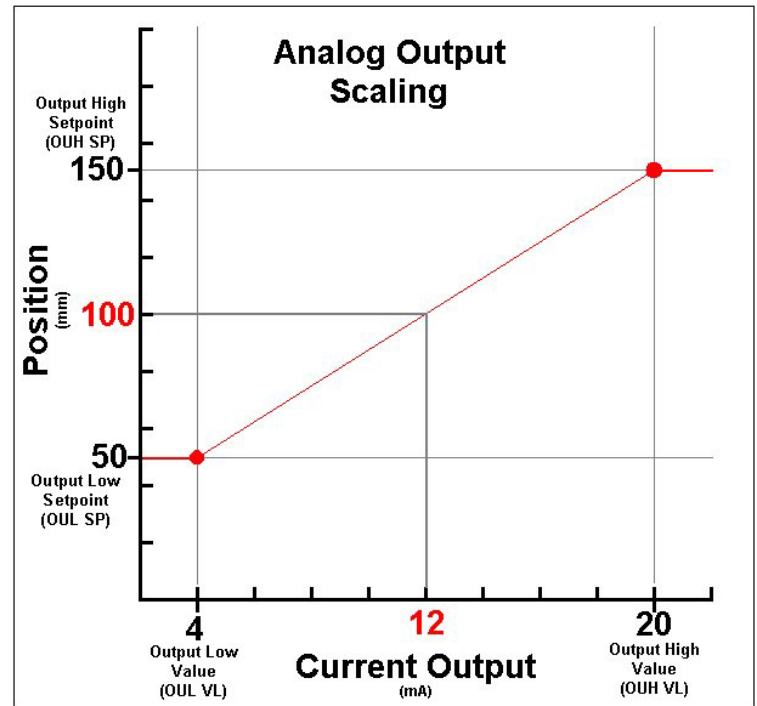

The positions are labeled “OUH SP” and “OUL SP” for Output High Set-point and Output Low Set-point, respectively. This nomenclature will be referenced as you are programming the analog output.

The current values are labeled “OUL VL” and “OUH VL” for Output Low Value and Output High Value, respectively. These will also be referenced as you are programming the analog output.

1. Press the “PROG.” and “↑” buttons at the same time.
2. The meter will read “CAL” (Calibrate); press “↑” to select “Yes,” and press “Prog.” to continue. (To cancel: press “↓” to select “No,” and press “Prog.”)

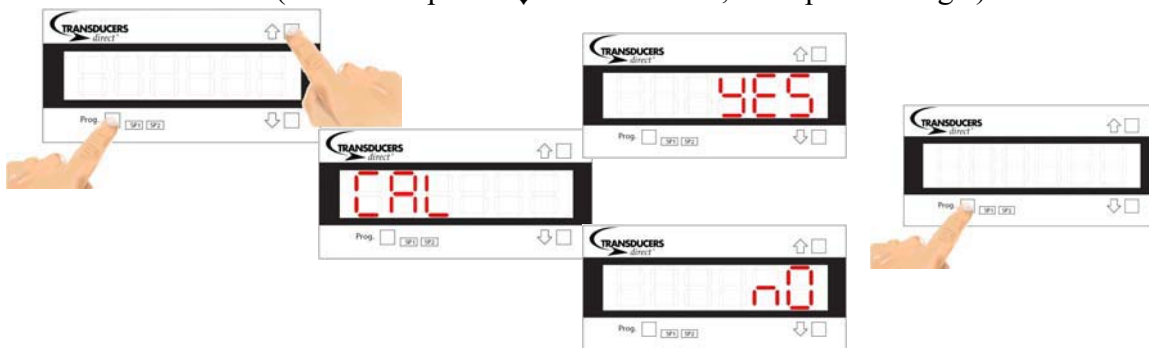

3. Next, the meter will alternate between “CAL IN” and “CAL OU” (Calibrate Input & Calibrate Output, respectively). At this point the analog output calibration (“CAL OU”) will be discussed. Press “↓” to select “CAL OU,” and press “Prog.” to continue.



4. The meter will alternate between “V” and “A” for Volts and Amps, respectively. This selects whether the analog output programming scale will be from 0 to 10 Volts (“V”) or 4 to 10 milliamps (“A”).
  - a. Press “Prog.” After making your selection.
  - b. Note: The jumper on the rear of the unit determines which mode (0 to 10 Volts or 0 to 20 mA) the meters output is actually in. (see “setting the jumpers for voltage or current output” section).

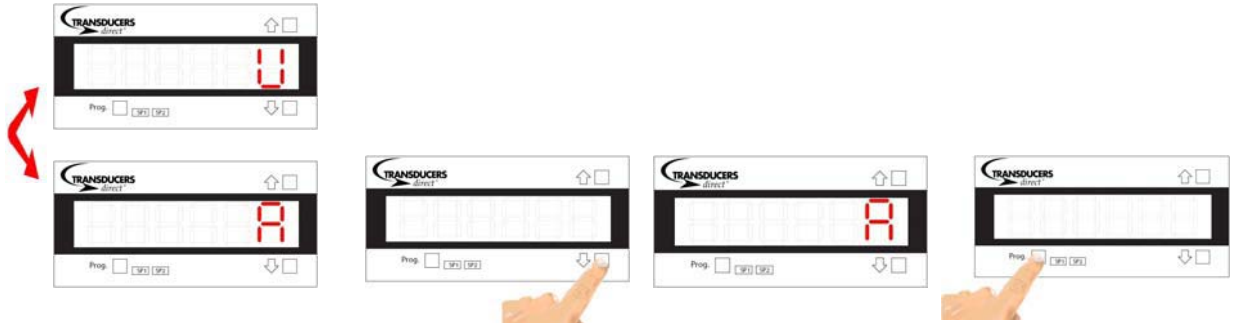

5. Next, the meter will alternate between “OUL SP” (Output Low Set-point, see analog output scaling graph) and the current set-point
  - a. Press “PROG.” to skip to the next digit; press “↑” or “↓” to change the value of that digit. Repeat until the desired number has been achieved.
  - b. When finished, press and hold “PROG.” for one second to end.

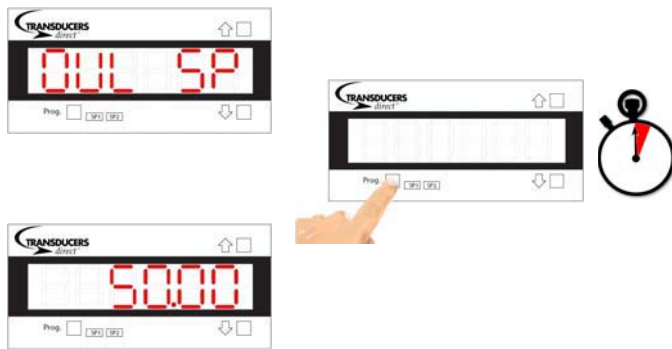

6. Next, the meter will alternate between “OUL VL” (Output Low Value, see analog output scaling graph) and the current set-point
  - a. Press “PROG.” to skip to the next digit; press “↑” or “↓” to change the value of that digit. Repeat until the desired number has been achieved.
  - b. When finished, press and hold “PROG.” for one second to end

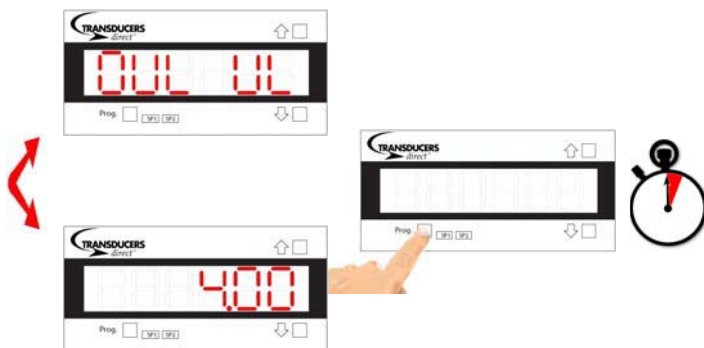

7. Next, the meter will alternate between “OUH SP” (Output High Set-point, see analog output scaling graph) and the current setpoint
  - c. Press “PROG.” to skip to the next digit; press “↑” or “↓” to change the value of that digit. Repeat until the desired number has been achieved.
  - d. When finished, press and hold “PROG.” for one second to end

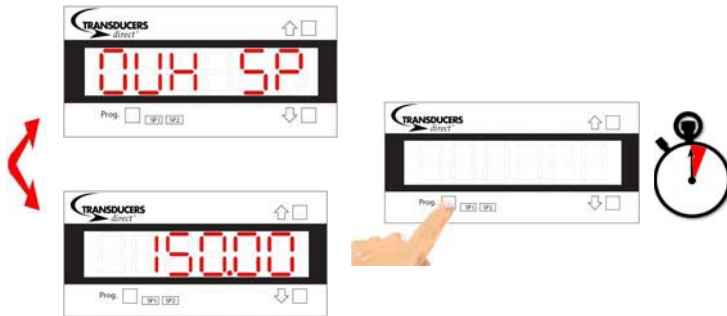

8. Next, the meter will alternate between “OUH VL” (Output High Value, see analog output scaling graph) and the current set-point
  - e. Press “PROG.” to skip to the next digit; press “↑” or “↓” to change the value of that digit. Repeat until the desired number has been achieved.
  - f. When finished, press and hold “PROG.” for one second to end

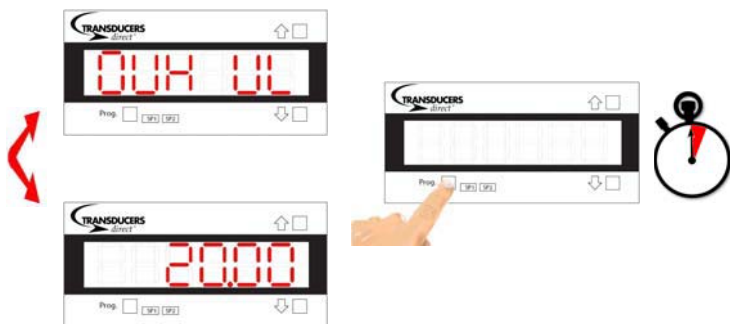

## TROUBLESHOOTING THE ANALOG METER:

The meter has two special modes to help determine if an unexpected reading or analog output is due to the setup programming (scalable inputs and outputs) or if there is an actual problem with the meter.

The first mode allows the raw input (either voltage or current) to be displayed on the screen. At this point the meter acts like a digital voltmeter. This allows the user to “see” what voltage the meter is reading.

Example:

Input: linear transducer, 100mm stroke, 0 to 10V output.

Input Scaling: Set up to read in mm (0 to 100mm)

Analog Output: 0 volts @ 0.0mm, 10 volts @ 50.0mm

When the transducer is at the midpoint of the stroke the display should read 50.0 and the input voltage (across pins 6 and 7) should be 5.0 volts.

In order to show the **input voltage or current** on the display press and hold “↑” for 5 seconds



To go back to the normal display mode press and hold “Prog.” for 5 seconds.

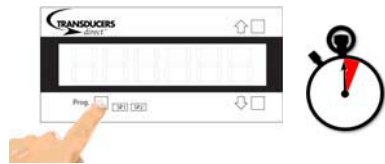

The second mode allows the raw output to be displayed on the screen. This option is only valid for meters that have the analog retransmission capability (TDRO10A2). This allows the user to “see” what output voltage the meter is supplying.

Using the setup from the example from above, when the transducer is at half of the stroke (50mm) the display should read 50.0, the input voltage (across pins 6 and 7) should be 5.0 volts and the analog output voltage (between pins 1 & 2) should be 10.0V (since the analog Output was set to 0 volts @ 0.0mm and 10 volts @ 50.0mm).

In order to show the **output voltage or current** on the display press and hold “↓” for 5 seconds

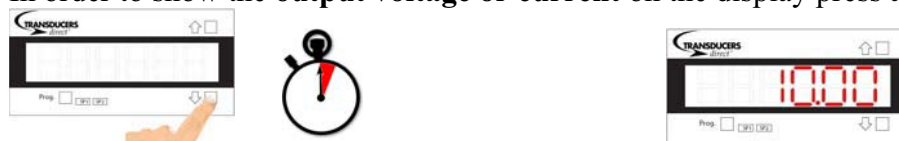

To go back to the normal display mode press and hold “Prog.” for 5 seconds.

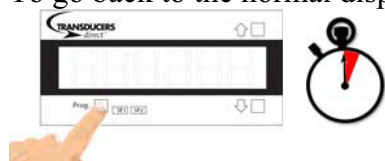

## SETTING THE JUMPERS FOR VOLTAGE OR CURRENT OUTPUT:

1. Locate the jumper (shown below) on the rear of the unit.
2. For voltage output (0 to 10 V), place the jumper around the left and center pins.
3. For current output (0 to 20 mA), place the jumper around the right and center pins.

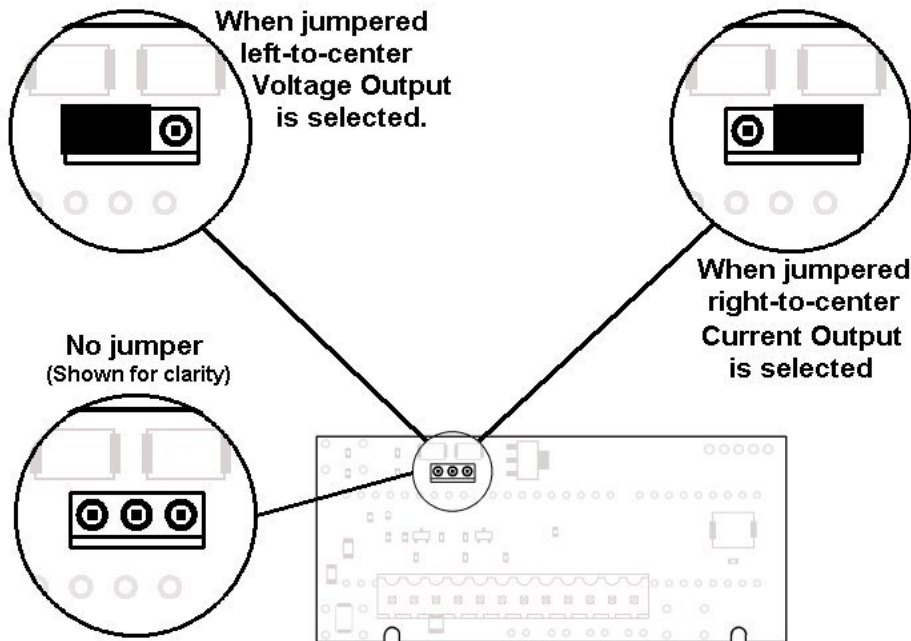

## POWER AND I/O CONNECTOR PINOUT:

The connector is located on the rear of the unit and is numbered from left to right as shown in the illustration below.

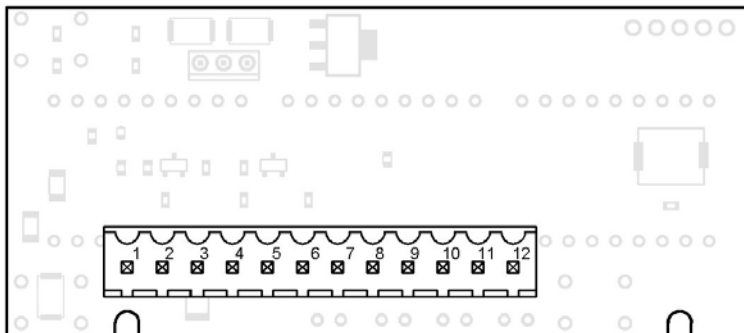

**Note:**  
By design the meter is not capable of reading a negative input voltage

### PINOUT FOR ANALOG VERSION

- Pin 1: Ana. Out – (TDRO10A2) or Dig. Out#4 (TDRO10A1)
- Pin 2: Ana. Out + (TDRO10A2) or Dig. Out#3 (TDRO10A1)
- Pin 3: Dig. Out #2.
- Pin 4: Dig. Out #1
- Pin 5: 4-20 mA Input
- Pin 6: 0-10 V Input

- Pin 7: Ground
- Pin 8: 10 V Ref.
- Pin 9: Ground
- Pin 10: +24 V Trans.
- Pin 11: Ground
- Pin 12: +24 V Sup.

### PANEL CUTOUT:

The meter mounts into a standard 1/8 DIN cutout. The illustration below shows the range (loose fit to snug fit) for the panel cutout. It is possible to snip off the eight DIN spacers on the plastic meter housing and use a square cutout (labeled Mosaic Fitting).

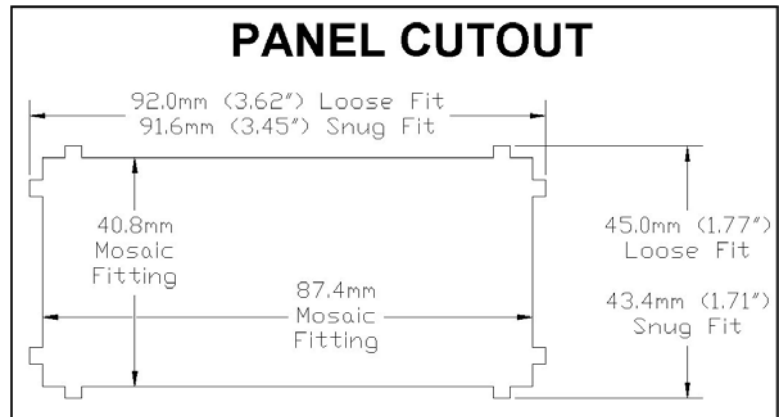

### METER INSTALLATION:

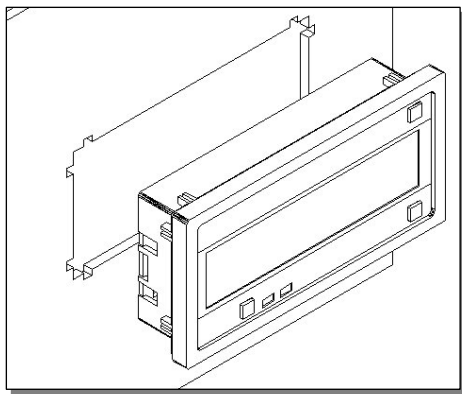

Insert the meter into the panel cutout described above. Make sure that the unit has been fully inserted and is flush with the panel face.

Install the provided mounting clips from the rear of the unit as shown below. Make sure that the clips are perpendicular to the side of the meter.

Tighten the mounting screws until the meter is secure. Do not over tighten the screws.

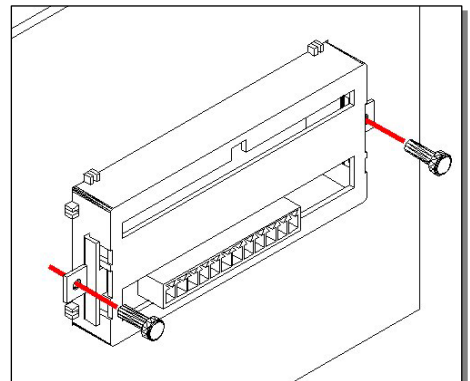
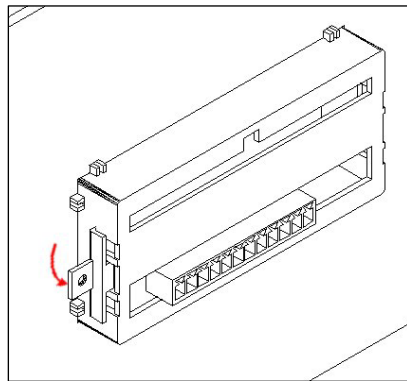
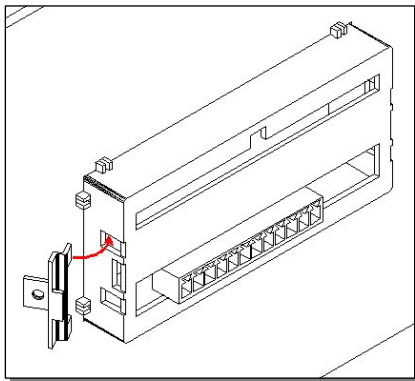

### METER DIMENSIONS:



## OPTIONAL ACCESSORIES:

### NEMA 4X COVER:

This rugged, impact resistant, clear lens cover is designed to be dust and water proof to NEMA 4 and IP65 standards. The lens cover consists of a base and cover with a cam hinge and key-lock locking device. An O-ring, or neoprene gasket forms a seal between the base and the panel. When opened, a cam hinge prevents the cover from closing until pushed closed. The cover has a tapered recess that, when closed, forms a capillary seal with a tapered ridge on the base. A capillary seal is created when capillary action causes a small amount of water to be drawn in between the two surfaces producing a water tight film around the sealing area. For those applications, such as food processing, where fluid residues are unacceptable, apply a light coating of clear silicone grease, or other approved sealant to the mating groove to prevent any ingress of liquid and enable the cover to withstand steam cleaning. Turning the key-lock tightens the cover to the base, ensuring seal integrity. A safety catch keeps the cover closed even when the key is turned to the open position and removed. The keyhole can also be used to attach a safety seal clip, preventing unauthorized opening.



1/8 DIN 96x48 mm (3.78"x1.89")

P/N: N4-96X48

