

# Temposonics®

## Magnetostrictive Linear-Position Sensors

R-Series Model RP and RH Sensors - Analog Output  
Position, Speed, Speed with Direction  
Single or Dual Magnet Positions



550992 D

### Product Specification



- Rugged industrial sensor
- Linear, absolute measurement
- LEDs for sensor diagnostics
- Non-contact sensing technology
- Non-linearity less than 0.01%
- Repeatability within 0.001%
- Direct Analog output, displacement + speed
- Dual magnet position measurement
- 100% field adjustable Null and Span setpoints

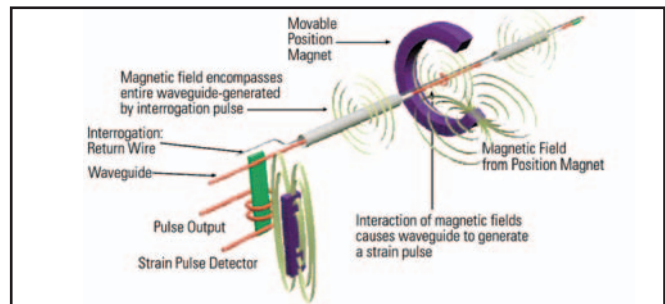

### The benefits of magnetostrictive sensing

#### R-Series linear-position sensors

- R-Series model RH and RP sensors are extremely robust and are ideal for continuous operation under harsh industrial conditions.
- Two standard sensor housings are available. The rod housing is capable of withstanding high pressures such as those found in hydraulic cylinders. The profile extrusion housing provides convenient mounting options and sliding magnets.
- The sensor head contains the active signal conditioning and a complete integrated electronics interface. Double shielding is used to ensure EMI protection for unsurpassed reliability and operating safety.

Temposonics linear sensors use the time-based magnetostrictive position sensing principle developed by MTS. Within the sensing element, a sonic strain pulse is induced in a specially designed magnetostrictive waveguide by the momentary interaction of two magnetic fields. One field comes from a movable permanent magnet that passes along the outside of the sensor. The other field comes from an “interrogation” current pulse applied along the waveguide. The resulting strain pulse travels at ultrasonic speed along the waveguide and is detected at the head of the

sensing element. The position of the magnet is determined with high precision and speed by accurately measuring the elapsed time between the application of the interrogation pulse and the arrival of the resulting strain pulse with a high speed counter. Using the elapsed time to determine position of the permanent magnet provides an absolute position reading that never needs recalibration or re-homing after a power loss. Non-contact sensing eliminates wear, and guarantees the best durability and output repeatability.



All specifications are subject to change. Please contact MTS for specifications that are critical to your needs.

## R-Series Analog sensor options, parameters and specifications

### Outputs

The R-Series analog sensor provides single or dual magnet sensor options along with one or two channel outputs.

The R-Series analog sensor can be ordered for a single-position magnet providing one displacement output, and/or one velocity output over the active stroke length.

The sensor can also be ordered for dual-position magnets providing two displacement outputs, or two velocity outputs, or one of each.

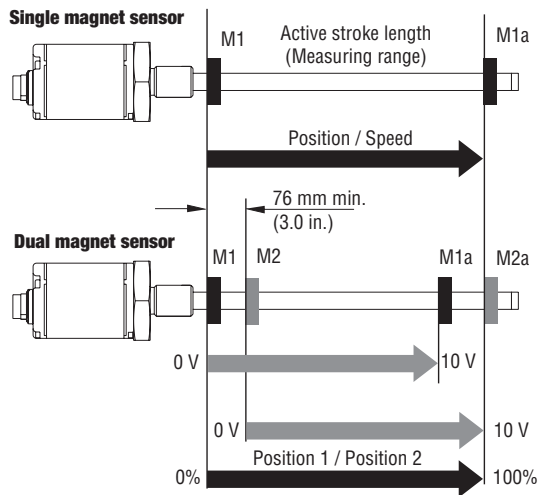

When using dual magnets, the minimum allowed distance between the magnets is 3.0 in. (76 mm) to maintain proper sensor output.

### Enhanced monitoring and diagnostics

#### Sensor status and diagnostic display

Integrated LEDs (green/red) provide basic visual feedback for normal sensor operation and troubleshooting.



Green	Red	Description
ON	OFF	Normal function (operation mode)
ON	Flashing	Magnet out of setup range
ON	ON	Magnet not detected or wrong quantity of magnets
Flashing	ON	Programming mode

### Parameter

### Specification

<b>Measured variables:</b>	Displacement, speed (magnitude), or velocity (with direction) for single or dual magnets
<b>Resolution:</b>	Position measurement: 16 bit; 0.0015% (minimum 1 µm) Speed measurement: 0.1 mm/s
<b>Non-linearity:</b>	< ± 0.01% full stroke (minimum ± 50 µm)
<b>Repeatability:</b>	< ± 0.001% full stroke (minimum ± 2.5 µm) Hysteresis: < 4 µm
<b>Outputs:</b>	Voltage: 0 to 10, 10 to 0, -10 to +10, +10 to -10 Vdc (minimum controller load >5k ohms) Current: 4(0) to 20 mA, 20 to 4(0) mA, (min./max. load 0/500 ohms)
<b>Position measurement:</b>	Range: Profile style 50 to 5080 mm (2 to 200 in.) Rod style 50 to 7620 mm (2 to 300 in.) Update time: 0.5 ms up to 1200 mm, 1.0 ms up to 2400 mm, 2.0 ms up to 4800 mm, 5.0 ms up to 7620 mm stroke length.
<b>Speed measurement:</b>	Range: 0.025 - 10 m/s (1.0 - 400.0 in./s) Deviation: < 0.5% Resolution: 0.1 mm/s (0.004 in./s) Update time: See position measurement
<b>Operating voltage:</b>	+24 Vdc nominal (-15 or +20%) Polarity protection: up to -30 Vdc Overvoltage protection: up to 36 Vdc Current drain: 100 mA typical Dielectric withstand voltage: 500 V (DC ground to machine ground)
<b>Operating conditions:</b>	Temperature: - 40 to +75 °C Relative humidity: 90% no condensation Temperature coefficient: < 30 ppm / °C Setpoint adjustment, (Null/Span): 100% of electrical stroke length. Min. 25 mm distance between setpoints. For dual magnet outputs: Min 76 mm distance between magnets.
<b>EMC test:</b>	Emissions IEC/EN 50081-1, Immunity IEC/EN 50082-2, IEC/EN 61000-4-2/3/4/6, level 3/4 criterion A, CE qualified
<b>Shock rating:</b>	100 g (single hit)/IEC standard 68-2-27 (survivability)
<b>Vibration rating:</b>	15 g/10-2000 Hz/IEC standard 68-2-6
<b>Connection type:</b>	6-pin male D60 connector or integral cable

#### PROFILE STYLE (RP MODEL)

<b>Electronic head:</b>	Aluminum housing Diagnostic display (LED's beside connector/cable exit)
<b>Sealing:</b>	IP 65
<b>Sensor extrusion:</b>	Aluminum (Temposonics profile style)
<b>Mounting:</b>	Adjustable mounting feet or T-slot nut (M5 threads) in base channel
<b>Magnet type:</b>	Captive-sliding magnet or floating (open ring) magnet

#### ROD STYLE (RH MODEL)

<b>Electronic head:</b>	Aluminum housing Diagnostic display (LED's beside connector/cable exit)
<b>Sealing:</b>	IP 67 or IP 68 for integral cable model
<b>Sensor rod:</b>	304L Stainless steel
<b>Operating pressure:</b>	350 bar static, 690 bar peak (5000 psi static, 10,000 psi peak)
<b>Mounting:</b>	Any orientation, threaded flange M18 x 1.5 or 3/4-16 UNF-3A
<b>Typical mounting torque:</b>	45 N-m (33 ft. - lbs.)
<b>Magnet type:</b>	Ring, floating (open ring) magnet, or magnet float

Sensor field programming

Temposonics R-Series Analog sensors are preconfigured at the factory by model number designation. For many applications, no adjustments are required for normal sensor installation and operation. If, however, sensor parameter changes are needed while in the field, the R-Series Analog sensor is easily programmed externally. There is no need to open the sensor's electronic housing.



**R-Series Analog PC Programming kit, Part no. 253309**  
For single or dual magnet sensors

This programming kit includes a wall adapter style power supply, serial converter box, two connection cables (wired for the LIN protocol), and the software CD-ROM. The serial converter box and one of the cables are required to communicate between a Windows PC and the sensor. When running the R-Series Analog PC Setup software many customized settings are possible for:

- Setpoint 1 (Null) and Setpoint 2 (Span) for single or dual magnets. (See the description for setpoints under the section, "R-Series Analog Handheld Programmer".)
- Output range settings for speed, or for speed with direction.
- Assign position or velocity output functions for the single or dual magnets, and for the one or two output channels. (Output function assignments are limited to the manufacturing build type of the sensor, see below.)
- Error output values when the magnet moves beyond the programmed setpoints.

Field programming to adjust the output values is available for any setting needed, within the selected output range. Each sensor's output range is selected from the available options when ordering a particular sensor model number, (see pages 7 and 8).

There are 6 different manufacturing build types used to provide for the various output ranges. These are:

Single Channel Output for either position or speed

- 1) Voltage output between 0 and +10 volts
- 2) Voltage output between -10 and +10 volts
- 3) Current output between 0 (or 4) and 20 mA

Two Channel Outputs for position and/or speed

- 4) Voltage outputs between 0 and +10 volts
- 5) Voltage outputs between -10 and +10 volts
- 6) Current outputs between 0 (or 4) and 20 mA

**Note:**

Field programming allows for numerous custom sensor configurations, however, please note that field programming can not be used to change the R-Series Analog sensor from one manufacturing build type to another.

**R-Series Analog handheld programmer (for single magnet sensors)**

The R-Series Analog handheld programmer (part number 253124) can be used to program the magnet positions for the start of output, (0% = 0 Vdc, -10 Vdc, 4 mA, or 0 mA), and the end of output, (100% = 10 Vdc or 20 mA), for the single magnet version of the R-Series Analog sensor.



**Handheld programmer, Part no. 253124**

Standard factory settings place the setpoint 1 (Null) and setpoint 2 (Span) at the limits of the sensor's active stroke range. For example, a sensor ordered with 4 - 20 mA output will be factory set for 4 mA output at the bottom limit of the stroke range at the "Null" position. Likewise, the 20 mA output will be factory set at the top limit of the stroke range at the start of the "dead zone".

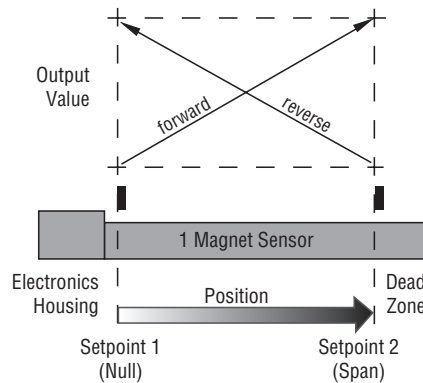

Setpoint 1 and setpoint 2 can be re-positioned for the actual measuring range needed anywhere within the active stroke length. (Note: The minimum distance allowed between setpoint 1 and setpoint 2 is 25 mm.) These adjustments are easily performed, even when the sensor is not directly accessible, by connecting the analog handheld programmer to the sensor's integral cable or extension cable.

**Windows sensor programming**

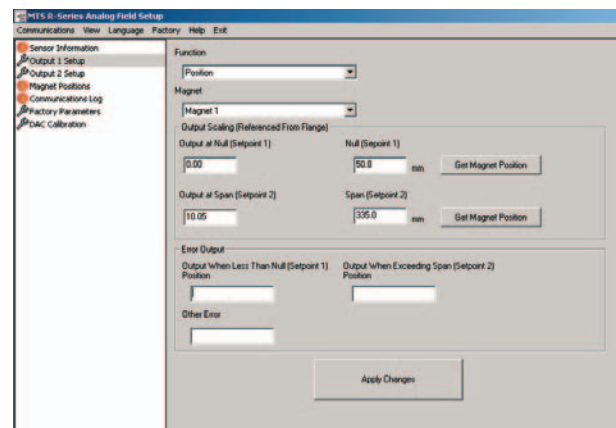

## Model RP profile-style sensor

The Temposonics model RP sensor offers modular construction, flexible mounting configurations and easy installation.

### Captive-sliding magnet

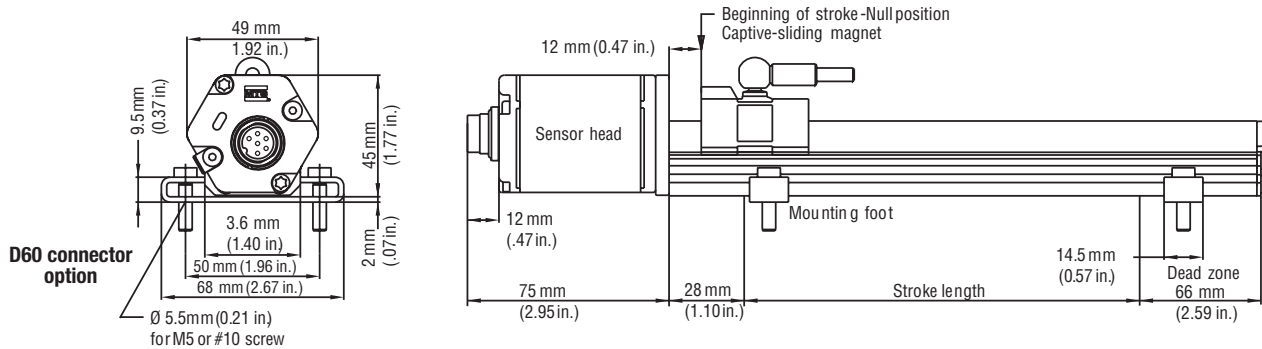

### Floating magnet (open ring)

#### R05 integral cable option

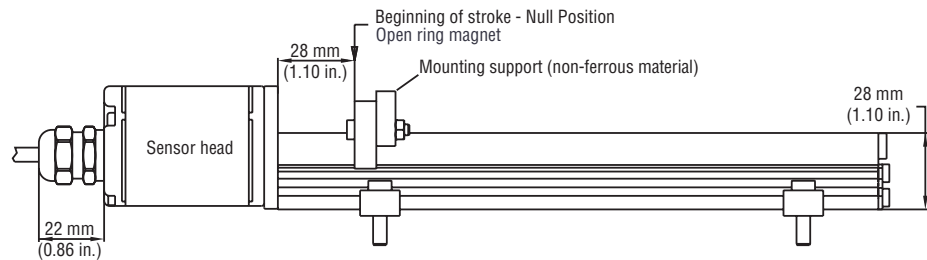
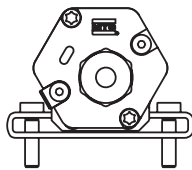

### Selection of position magnets (included with sensor)

A choice of two magnet mounting configurations are available with the profile-style sensor; the captive-sliding magnet or the floating (open ring) magnet.

Captive-sliding magnets utilize slide bearings of special material that reduce friction, and if required, help mitigate dirt build up. The slide bearings are designed to operate dry, requiring no external lubrication or maintenance.

The floating magnet (open ring) mounts on the moving machine part and travels just above the sensor's profile extrusion. The open ring magnet (style M) requires a minimum distance away from ferrous metals to allow proper sensor output. It must be mounted using non-ferrous screws and a non-ferrous support bracket, or utilize a non-ferrous spacer of at least 5 mm (0.2 in.) thickness.

#### Captive-sliding magnet, style S part no. 252182

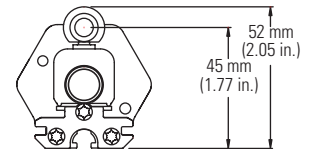
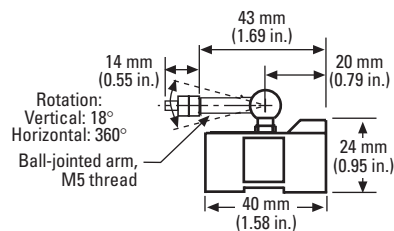

#### Captive-sliding magnet, style V part no. 252184

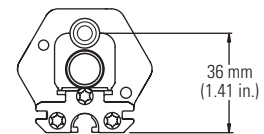
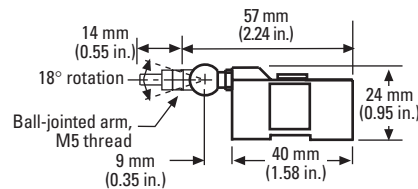

#### Floating (open ring) magnet, style M part no. 251416-2

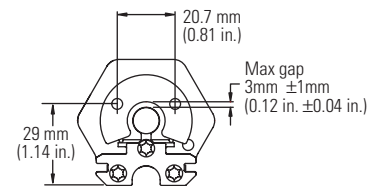
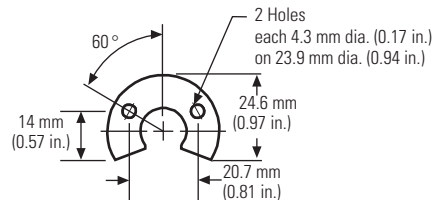

ID: 13.5 mm (0.53 in.)  
OD: 32.8 mm (1.29 in.)  
Thickness: 7.9 mm (0.312 in.)

## Model RH rod-style sensor

The Temposonics R-Series rod-style sensor (Model RH) offers modular construction, flexible mounting configurations, and easy installation. It is designed for internal mounting in applications where high pressure conditions exist, (5000 psi continuous, 10,000 psi spike), such as hydraulic cylinders. The Model RP sensor may also be mounted externally in many applications.

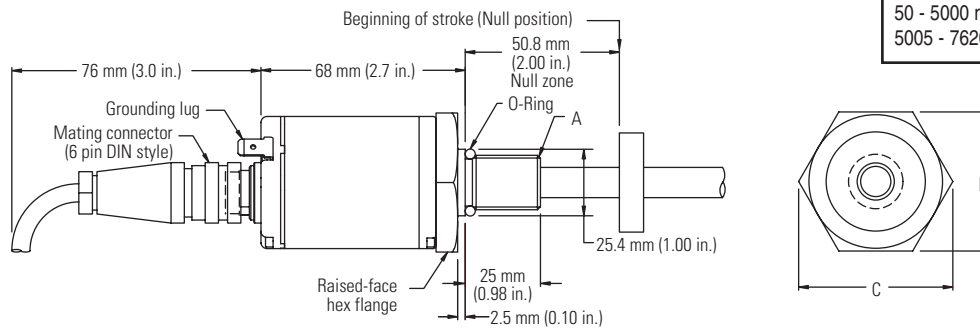
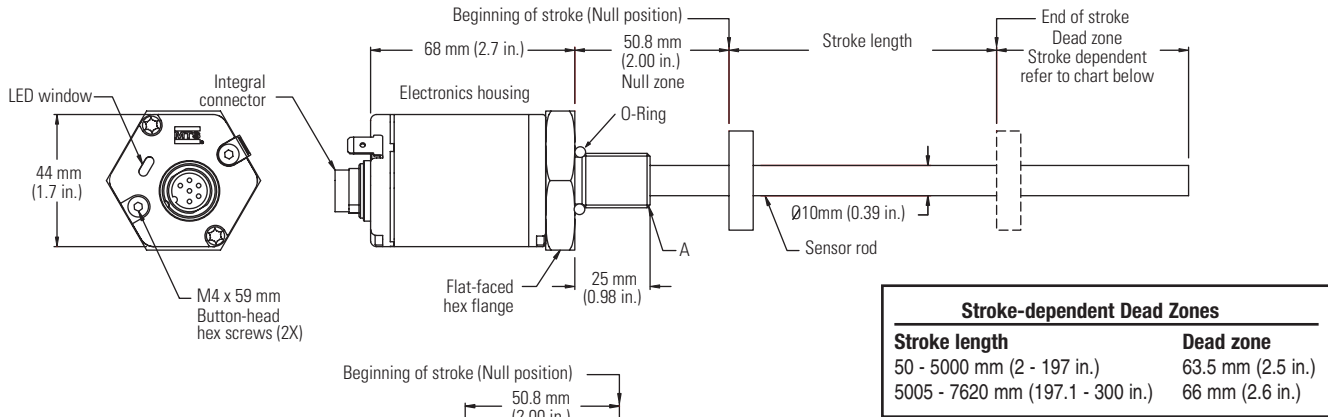

Housing style Flange type	Description	A Flange threads	B Dimensions	C Dimensions
T	US customary threads with raised-face hex	3/4"-16 UNF-3A	44.5 mm (1.75 in.)	51 mm (2.0 in.)
S	US customary threads with flat-faced hex	3/4"-16 UNF-3A	44.5 mm (1.75 in.)	51 mm (2.0 in.)
M	Metric threads with flat-faced hex	M18 x 1.5	46 mm (1.81 in.)	53 mm (2.1 in.)

## Selection of position magnets (must order separately)

Magnets must be ordered separately with model RH position sensors. The standard ring magnet (part number 201542-2) is suitable for most applications.

### Standard-ring magnet part no. 201542-2

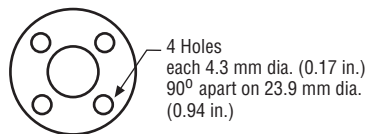

ID: 13.5 mm (0.53 in.)  
OD: 32.8 mm (1.29 in.)  
Thickness: 7.9 mm (0.312 in.)

### Ring magnet part no. 400533



ID: 13.5 mm (0.53 in.)  
O.D.: 25.4 mm (1.0 in.)  
Thickness: 7.9 mm (0.312 in.)

### Magnet float (level sensing applications) part no. 251447

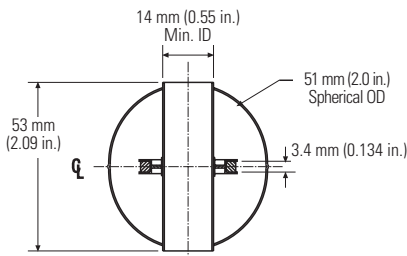

Specific Gravity: 0.70 max.  
Pressure: 870 psi max.  
(Float for use with rod-style sensors in hydraulic fluid or fresh water applications only)

### Floating (open ring) magnet, style M part no. 251416-2

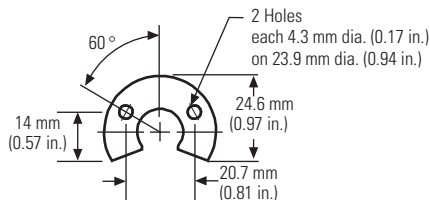

ID: 13.5 mm (0.53 in.)  
OD: 32.8 mm (1.29 in.)  
Thickness: 7.9 mm (0.312 in.)

### Magnet spacer (non-ferrous spacer for use with standard ring magnet) part no. 400633



ID: 14.3 mm (0.56 in.)  
O.D.: 31.8 mm (1.25 in.)  
Thickness: 3.2 mm (0.125 in.)

## Mounting, wiring and magnets

### Profile-style sensor mounting

#### Flexible installation in any position

Temposonics model RP profile-style sensors offer two basic mounting methods; side grooves for use with mounting feet or a bottom groove that accepts special T-slot nuts. Both the mounting feet and T-slot nuts can be positioned along the sensor extrusion to best secure the sensor for each particular application.

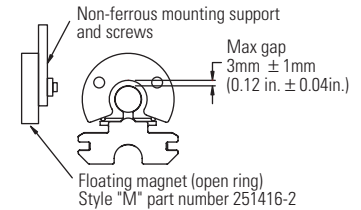
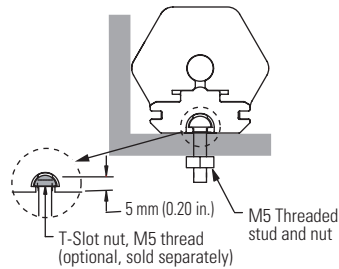
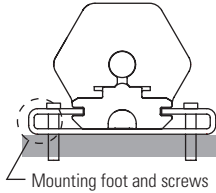

#### Note:

Temposonics Model RP sensors include two mounting feet (part no. 400802) for sensors up to 1250 mm (50 in.) One additional mounting foot is included for every additional 500 mm (20 in.)

### Rod-style sensor mounting

The position magnet requires minimum distances away from ferrous metals to allow proper sensor output. The minimum distance from the front of the magnet to the cylinder end cap is 15 mm (0.6 in.). The minimum distance from the back of the magnet to the piston head is provided by the non-ferrous spacer, i.e. 3.2 mm (0.125 in.).

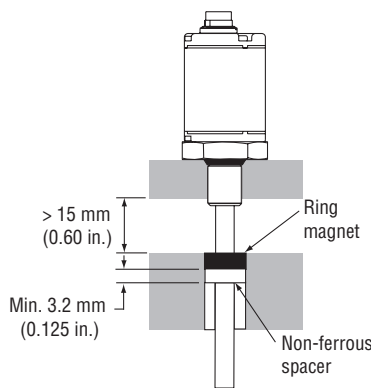

### Sensor integral connector (D60 Male)

Male Integral D6 connector pin-out as viewed from the end of the sensor

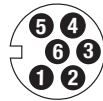

Pin no.	Wire color	Function
1	Gray	<b>Analog outputs</b> Output 1/Position #1: 0 to 10, 10 to 0, -10 to +10, +10 to -10V 4 to 20, 20 to 4, 0 to 20, 20 to 0 mA
2	Pink	Return for pin 1
3	Yellow	Output 2/Position #2 or Speed: 0 to 10, 10 to 0, -10 to +10, +10 to -10V 4 to 20, 20 to 4, 0 to 20, 20 to 0 mA
4	Green	Return for pin 3
5	Red or Brown	+24 Vdc (-15 / +20%)
6	White	DC Ground (for supply)

#### Note:

When using the single channel output (pins 1 and 2), the unused pins for output 2 (pins 3 and 4) should be left floating (unconnected), unless sensor programming is being used.

### Cylinder installation

When used for direct stroke measurement in fluid cylinders, the sensor's stainless steel rod installs into a bore in the piston head/rod assembly as illustrated. This method guarantees a long-life and trouble-free operation.

The sensor cartridge can be removed from the flange and rod housing while still installed in the cylinder. This procedure allows quick and easy sensor cartridge replacement, without the loss of hydraulic pressure.

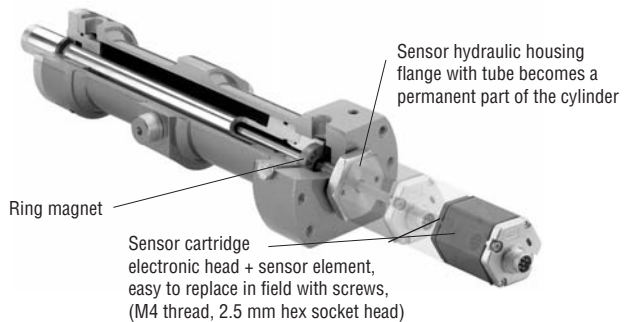

### Cable connectors (Field installed D6 female)

Mates with sensor's Integral connector

**D6 straight-exit connector part no. 560700**

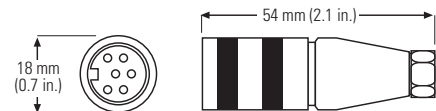

**D6 90° connector part no. 560778**

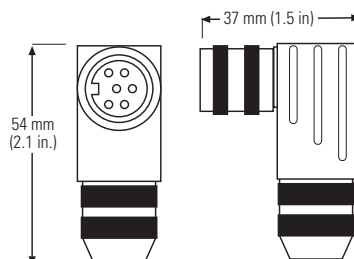

## How to order

3 to 7 digit code depending on output selected

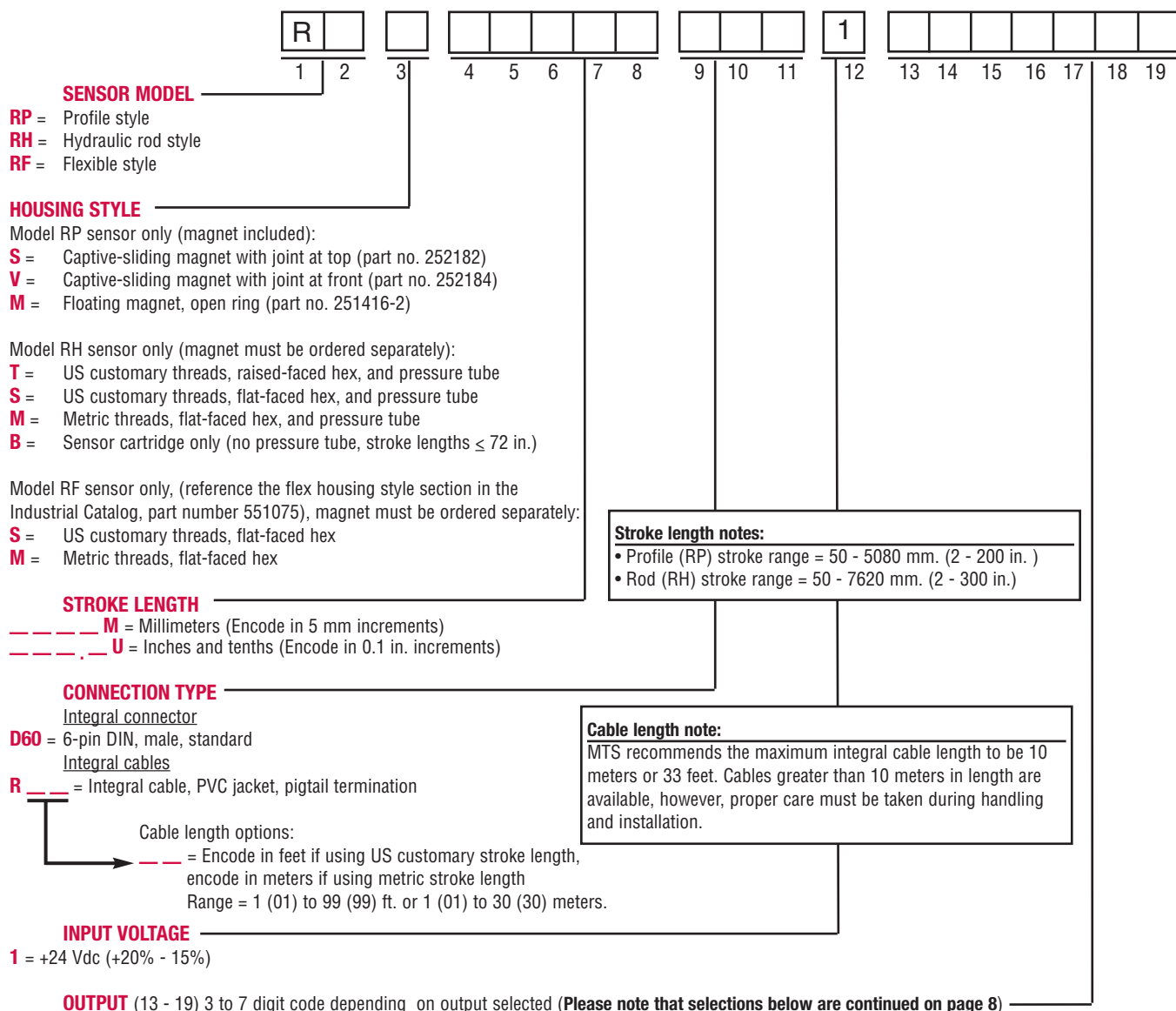

### 1 output channel with 1 magnet (3 digit code)

Output #1 = magnet position

<b>V01</b> = 0 to +10 Vdc	<b>A01</b> = 4 to 20 mA
<b>V11</b> = +10 to 0 Vdc	<b>A11</b> = 20 to 4 mA
<b>V21</b> = -10 to +10 Vdc	<b>A21</b> = 0 to 20 mA
<b>V31</b> = +10 to -10 Vdc	<b>A31</b> = 20 to 0 mA

### 2 output channels with 2 magnets \* (3 digit code)

Output #1 = magnet #1 position

Output #2 = magnet #2 position

<b>V02</b> = 0 to +10 Vdc	0 to +10 Vdc
<b>V12</b> = +10 to 0 Vdc	+10 to 0 Vdc
<b>V22</b> = -10 to +10 Vdc	-10 to +10 Vdc
<b>V32</b> = +10 to -10 Vdc	+10 to -10 Vdc
<b>A02</b> = 4 to 20 mA	4 to 20 mA
<b>A12</b> = 20 to 4 mA	20 to 4 mA
<b>A22</b> = 0 to 20 mA	0 to 20 mA
<b>A32</b> = 20 to 0 mA	20 to 0 mA

\* Standard factory settings for the setpoint values are the same for both magnets, i.e. both magnets have setpoint 1 at the null position, and setpoint 2 at the start of the dead zone. If needed, the setpoint values for each magnet can be reprogrammed in the field to best fit the application, (see page 4 for more information). For proper sensor output, the minimum allowed distance between the magnets is 3.0 in. (76 mm).

## How to order (continued)

**OUTPUT** (13 - 19) 3 to 7 digit code depending on output selected (**Please note that selections below are continued from the previous page**)

**2 output channels with 1 magnet (7 digit code, fill in the blanks with the desired maximum speed value as described below)**

Output #1 = magnet position	Output #2 = speed magnitude		
<b>V01</b> _____ = 0 to +10 Vdc	+10 (towards head)	0 (at rest)	+10 (towards tip) Vdc
<b>V11</b> _____ = +10 to 0 Vdc	+10 (towards head)	0 (at rest)	+10 (towards tip) Vdc
<b>A01</b> _____ = 4 to 20 mA	20 (towards head)	4 (at rest)	20 (towards tip) mA
<b>A11</b> _____ = 20 to 4 mA	20 (towards head)	4 (at rest)	20 (towards tip) mA

Output #1 = magnet position	Output #2 = Velocity (speed with direction)		
<b>V41</b> _____ = 0 to +10 Vdc	0 (towards head)	5 (at rest)	+10 (towards tip) Vdc
<b>V51</b> _____ = +10 to 0 Vdc	+10 (towards head)	5 (at rest)	0 (towards tip) Vdc
<b>V61</b> _____ = 0 to +10 Vdc	-10 (towards head)	0 (at rest)	+10 (towards tip) Vdc
<b>V71</b> _____ = +10 to 0 Vdc	+10 (towards head)	0 (at rest)	-10 (towards tip) Vdc
<b>V81</b> _____ = -10 to +10 Vdc	-10 (towards head)	0 (at rest)	+10 (towards tip) Vdc
<b>V91</b> _____ = +10 to -10 Vdc	+10 (towards head)	0 (at rest)	-10 (towards tip) Vdc
<b>A41</b> _____ = 4 to 20 mA	4 (towards head)	12 (at rest)	20 (towards tip) mA
<b>A51</b> _____ = 20 to 4 mA	20 (towards head)	12 (at rest)	4 (towards tip) mA

Output #1 = magnet position (forward-acting)	Output #2 = magnet position (reverse-acting)
<b>V03</b> = 0 to +10 Vdc (3 digit code)	+10 to 0 Vdc

**For sensor models with speed output, fill in the blanks for the desired maximum speed value as shown below.**

For US customary stroke lengths, encode speed for in./s as follows:

\_\_\_\_\_ = Speed output max. (fill in remaining 4 blanks with desired max. speed value)

Available range for US customary stroke lengths is 1.0 to 400.0 in./s, (0010 ... 4000)

Example: For max. speed of 12.0 in./s, and output produced =

[-10(towards head) ... 0(at rest) ... +10(towards tip) Volts] Encode: V 6 1 0 1 2 0 or V 8 1 0 1 2 0

For metric stroke lengths, encode speed for m/s (range 1) or mm/s (range 2) as follows:

**Speed range #1, (0 \_\_\_\_\_)**

0 \_\_\_\_\_ = Speed output max. (fill in the remaining 3 blanks with desired max. speed value)

Speed range 1 for metric stroke lengths is 0.1 to 10.0 m/s, (0001 ... 0100)

Example: For max. speed of 5.5 m/s, and output produced =

[+10(towards head) ... 0(at rest) ... +10(towards tip) Volts], Encode: V 0 1 0 0 5 5

**Speed range #2, (1 \_\_\_\_\_)**

1 \_\_\_\_\_ = Speed output max. (fill in remaining 3 blanks with desired max. speed value)

Speed range 2 for metric stroke lengths is 25 to 90 mm/s, (1025 ... 1090)

Example: For max. speed of 50 mm/s, and output produced =

[4(towards head) ... 12(at rest) ... 20(towards tip) mA], Encode: A 4 1 1 0 5 0

Field programming notes:

- 1) Sensor models ordered with one output channel can not be reprogrammed in the field to provide a second output channel.
- 2) Sensor models ordered with positive only output voltages can not be reprogrammed in the field to include negative output voltages.
- 3) Sensor models ordered with both positive and negative output voltages can be reprogrammed in the field for positive only voltages, or negative only voltages, however, output resolution is then reduced.

## How to order (continued)

### Accessories

<b>Description</b>	<b>Function/Notes</b>	<b>Part no.</b>
Mounting feet, standard (spares)	Model RP sensors come with mounting feet (see page 6).	400802
Base channel T-slot nut	Nut for mounting model RP sensors. Requires M5 screw (see page 6).	401602
Hex jam nut	3/4 - 16 UNF nylon insert locknut for use with model RH sensors with style "T" or "S" housing	500015
O-Ring (spare)	For use with model RH sensors with style "T" or "S" housing	560315
O-Ring (spare)	For use with model RH sensors with style "M" housing	401133
Joint-rod Sleeve (1 in.)	For use with model RP sensors with "S" or "V" style magnets	401603
Ball-jointed arm, straight	For use with model RP sensors with "S" or "V" style magnets	401913

### Magnets and float options

<b>Description</b>	<b>Function/Notes</b>	<b>Part no.</b>
Small open ring (model RP spare)	Magnet style M, "floating" magnet used with model RH and RP sensors.	251416-2
Small ring magnet	Standard magnet for model RH sensors.	201542-2
Magnet float	For use with RH sensors used to measure liquid level	251447
Captive-sliding magnet (spare)	Style S captive-sliding magnet with joint at top. Comes with RP sensors.	252182
Captive-sliding magnet (spare)	Style V captive-sliding magnet with joint at front. Comes with RP sensors.	252184
Magnet spacer	For use with standard ring magnet, part no. 201542-2.	400633
Collar	Provides end of stroke "stops" for magnet float, part number 251447.	560777
Magnet mounting screws	Used to mount the standard ring magnet, part no. 201542-2. (4 screws required)	560357

### Field-installed connectors

<b>Description</b>	<b>Function/Notes</b>	<b>Part no.</b>
6-pin DIN connector, 90°	Female, 90° exit, mates to D60 connection type (see page 6)	560778
6-Pin DIN connector, straight	Female, straight exit, mates to D60 connection type (see page 6)	560700

### Programming tools

<b>Description</b>	<b>Function/Notes</b>	<b>Part no.</b>
R-Series Analog Hand Held Programmer	For adjusting null (setpoint 1) and span (setpoint 2) on R-Series analog sensors.	253124
R-Series Analog PC Programming kit	Includes serial converter, power supply, programming cables, and software CD.	253309

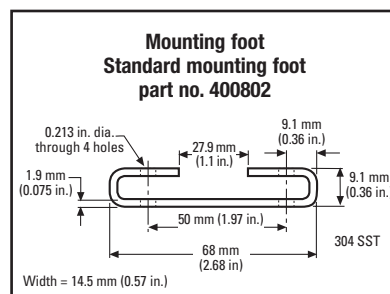
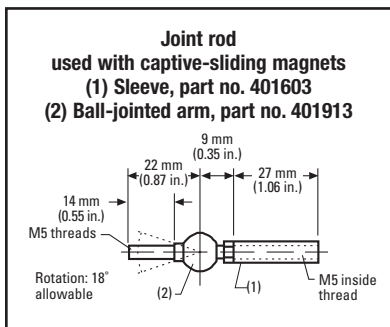

### Optional extension rods (for use with captive-sliding magnets)

<b>Extension rod lengths</b>	<b>Part no.</b>	<b>Extension rod lengths</b>	<b>Part no.</b>
60.3 mm (2.375 in.)	401768-2	390.5 mm (15.375 in.)	401768-15
85.7 mm (3.375 in.)	401768-3	466.7 mm (18.375 in.)	401768-18
111.1 mm (4.375 in.)	401768-4	517.5 mm (20.375 in.)	401768-20
161.9 mm (6.375 in.)	401768-6	542.9 mm (21.375 in.)	401768-21
187.3 mm (7.375 in.)	401768-7	619.1 mm (24.375 in.)	401768-24
212.7 mm (8.375 in.)	401768-8	771.5 mm (30.375 in.)	401768-30
238.1 mm (9.375 in.)	401768-9	923.9 mm (36.375 in.)	401768-36
263.5 mm (10.375 in.)	401768-10	1076.3 mm (42.375 in.)	401768-42
314.3 mm (12.375 in.)	401768-12	1228.7 mm (48.375 in.)	401768-48
365.1 mm (14.375 in.)	401768-14	1533.5 mm (60.375 in.)	401768-60

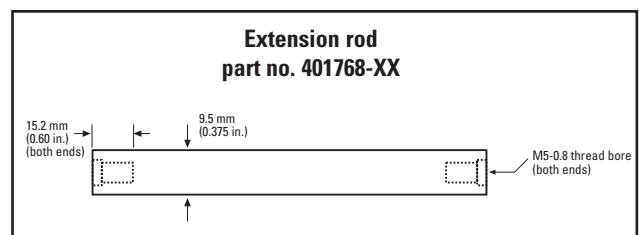

## How to order (continued)

### Extension cable with connectors for the D6, (D60), connection type

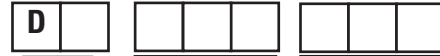

#### SENSOR CONNECTION TYPE

- D6** = Female connector, (straight exit), and standard (part no. 530026) cable (PVC jacket) for sensors with D6 or D60 connector
- DA** = Female connector, (90° exit), and standard (part no. 530026) cable (PVC jacket) for sensors with D6 or D60 connector
- DJ** = Female connector, (straight exit), and (part no. 530045) cable, (black polyurethane jacket for higher resistance to moisture and oil), for sensors with D6 or D60 connector
- DK** = Female connector, (90° exit), and (part no. 530045) cable, (black polyurethane jacket for higher resistance to moisture and oil), for sensors with D6 or D60 connector

#### CABLE LENGTHS

*For standard length cables up to 100 ft*

- 005** = 5 ft.                      **050** = 50 ft.  
**015** = 15 ft.                     **100** = 100 ft.  
**025** = 25 ft.

*For custom length cables over 100 ft*

--- = Cable length (maximum cable length is dependent on the output selected; consult MTS Applications Engineering.)

#### CABLE TERMINATION (2 or 3 characters depending on option selected)

- P0** = Pigtail connection, (no connector).
- D6M** = D6 male connector, (straight exit). Only available with the D6 option above.
- D6F** = D6 Female connector, (straight exit). Only available with the D6 option above.
- DAF** = D6 Female connector, (90 degrees exit). Only available with the DA option above.

Part Number: 09-06 550992 Revision D

Temposonics and MTS are registered trademarks of MTS Systems Corporation.

All other trademarks are the property of their respective owners.

All Temposonics sensors are covered by US patent number 5,545,984. Additional patents are pending.

Printed in USA. Copyright © 2006 MTS Systems Corporation. All Rights Reserved.



**UNITED STATES**  
MTS Systems Corporation  
Sensors Division  
3001 Sheldon Drive  
Cary, NC 27513  
Tel: (800) 633-7609  
Fax: (919) 677-0200  
(800) 498-4442  
www.mtssensors.com  
sensorsinfo@mts.com

**GERMANY**  
MTS Sensor Technologie  
GmbH & Co. KG  
Auf dem Schuffel 9  
D-58513 Lüdenscheid  
Tel: +49 / 23 51 / 95 87-0  
Fax: +49 / 23 51 / 56 491  
www.mtssensor.de  
info@mtssensor.de

**JAPAN**  
MTS Sensors Technology  
Corporation  
Ushikubo Bldg.  
737 Aihara-cho, Machida-shi  
Tokyo 194-0211, Japan  
Tel: + 81 (42) 775 / 3838  
Fax: + 81 (42) 775 / 5516  
www.mtssensor.co.jp  
info@mtssensor.co.jp