

O^{2D}S 730



Pag 1 / 4

File O2DS_730

Documento aziendale - La Societa' tutelera' i propri diritti a termini di Legge

Optical 2D - Profile Scanner

O^{2D}S 730



formato
A4
portr.

dimens.
210x297

mod.
FA4D00



Gordy's Sensors

5772 Smaller Rd, Johnstown, OH 43031 Phone: (740) 967-2283 Fax: (740) 967-2855
Website: www.gordyssensors.com or Email: sales@gordyssensors.com

REV	DESCRIZIONE	COMP	VERIF	APPR	DATA
-----	-------------	------	-------	------	------



An Optical 2D / Profile Scanner using Laser Triangulation with an Oscillating Mirror, a CCD - Line Scan Camera & Advanced Digital Signal Processing and Integrated with Windows software for output.

Specification

Measurement data

Measuring range (radial distance)	380-1080 mm
Standard 10° Scan arch	± 5°
Length of scans close by	66 mm
Length of scans far away	188 mm
Maximum 50° Scan arch	± 25°
Length of scans close on	321 mm
Length of scans far away	913 mm
Polar distance:	
Resolution *)	0.5 mm
Reproducibility *)	± 0.5 mm
Linearity *)	± 1 mm
Scan rate	600 or 300 scans/min.
Angular resolution:	10° arch < 0,08° or 0,04°
Angular resolution:	50° arch < 0,4° or 0,2°
Updating frequency	2000 Hz
Temperature deviation	± 0.03% of FS/°C
Laser spot size	app. Ø 3 mm

*) Static measurement on white paper without any averaging.

Environment data

Light source Visible laser	(670nm)
Laser protection class	IEC 2
Operating temperature	0 - +45 °C
Storage temperature	-20 - +50 °C
Humidity (non condensing)	Max 90 % RH
Degree of protection	IEC IP64

Physical data

Dimensions	187×192×50 mm
Weight excl. Cable	2300 g
Cable length	2.5 m
Housing	Steel/aluminium/glass

Electrical data

Serial output	RS232 or RS422/485
Baud rate	115200
Supply voltage	24 VDC ± 10 %
Power consumption,max	12 W

formato
A4
portr.

dimens.
210x297

mod.
FA4D00

REV	DESCRIZIONE	COMP	VERIF	APPR	DATA
-----	-------------	------	-------	------	------

O^{2D}S 730



Pag 3 / 4

File O2DS_730

Documento aziendale - La Societa' tutelera' i propri diritti a termini di Legge

Dimensions

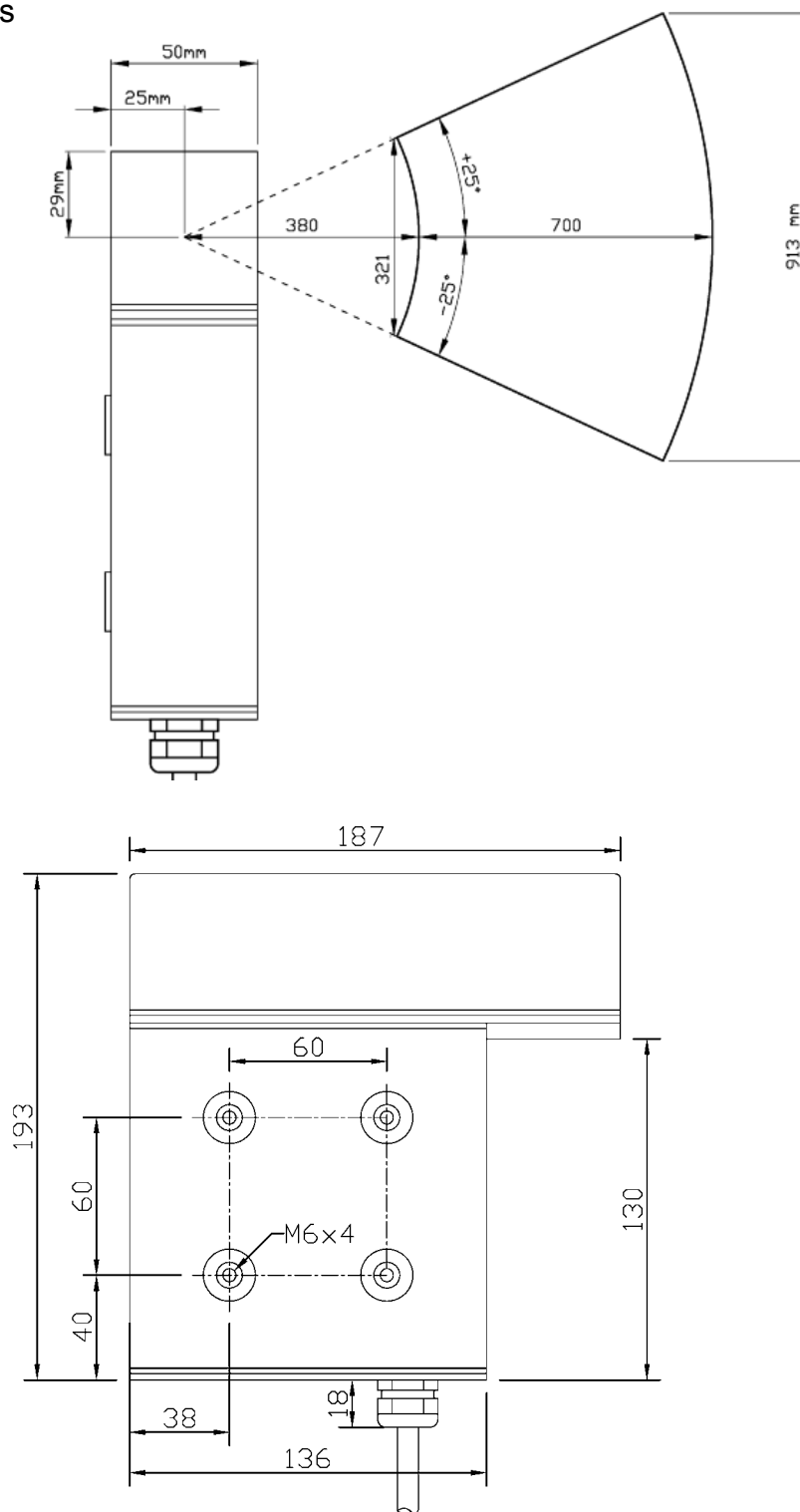

formato
A4
portr.

dimens.
210x297

mod.
FA4D00

REV DESCRIZIONE

COMP

VERIF

APPR

DATA



General description

The O^{2D}S sensor is an optical measuring device for non-contact precision measurement in two dimensions. The measurement is performed by oscillating the triangulation plane over 10° (max. 50°). A fine collimated or focused laser beam is diffusely reflected from the surface of almost any kind of material or fluid, and a CCD-camera records the image through an objective. This makes it possible for a Digital Signal Processor to calculate the (radial) distance from the centre of the mirror axis to the object surface, as well as keeping track of the angular reference position.

The O^{2D}S measuring system is a compact unit where optics, CCD-camera, and digital signal processing electronics all are integrated in the sensor housing. The schematic drawing to the right shows the O2DS 130 scanner seen from the side. It is here indicated how the triangulation plane, with this orientation of the scanner, can sweep (maximum) from minus 25° below the horizontal X-plane up to plus 25° above the horizontal X-plane. The distance data is available with a measuring frequency of 2 kHz as a digital signal, and presently for Windows applications only.

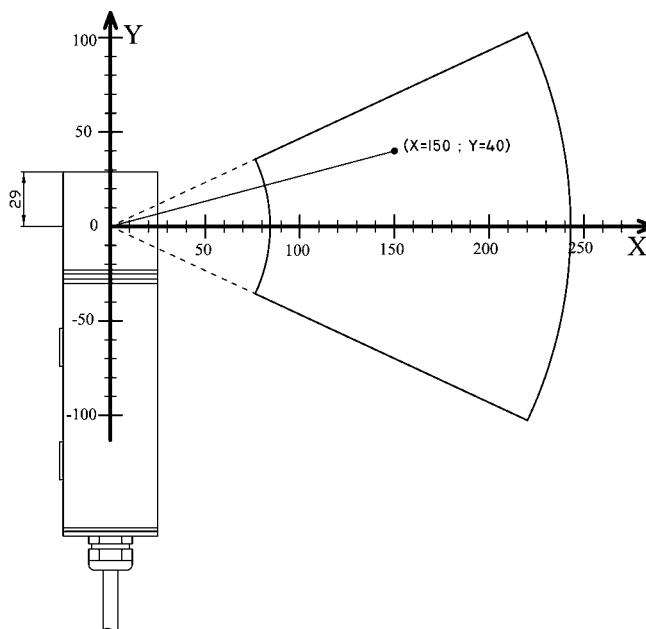

The scanner is delivered with diskettes containing a Windows test/demo program as well as the DLL file. The PC program receives output data from the scanner over the RS232 or RS422/485 interface and a COM port, and presents the measured distance to the object with the aid of DLL software support that comes with the scanner. The software either converts polar coordinates of a measurement point to orthogonal X, Y-coordinates or presents a profile (table of X, Y-values) for each sweep from one side to the other. The user can within the application program specify the seize of the Y-increment and thus the length of the output table containing the profile data.

The O^{2D}S scanner is developed for the need of 2D- / profile-measurement in any kind of industrial application. The ruggedly constructed scanner is designed to give a very reliable measuring performance with good measuring accuracy. With output data in the software-converted form, the Y-coordinates can be used for width/high measurement with a resolution dependent of the user chosen scan arch. By combining the X-coordinates of the profile data from two scanners, width data can be computed and presented in connection with the edge profiles measured from both sides of the object.

formato
A4
portr.

dimens.
210x297

mod.
FA4D00

REV	DESCRIZIONE	COMP	VERIF	APPR	DATA
-----	-------------	------	-------	------	------

