



MicroSpeed 196 Controller



- Compatible with all variable-speed drives.
- Keypad/display menus and features.
- Setup, calibration and diagnostic utilities.
- Master, ratio-follower modes.
- Multiple set-points.
- Switch-input functions.
- NPN-output functions.
- Serial communications/Modbus.

Product Information

Description

The MS196 is a powerful and versatile tool for building numerous closed-loop processes. Closed-loop control capabilities include electronic line shaft/gearing, and bi-directional control. The MS196 accepts single channel encoder signals and also provides the encoder power, which makes it ideal for new or existing systems. The MS196 supplies an isolated 0 ± 10 Vdc speed reference signal to the drive, making it compatible with virtually any variable speed drive (AC, DC, or servo).

Operating Modes

Master

- The MS196 maintains the desired set point speed.
- Feedback signal inputs to the MS196.
- The user may easily change the set point by entering the desired new value into the front panel keypad.

Ratio Follower

- The MS196 achieves true electronic gearing by precisely setting follower ratio to master speed, resulting in zero cumulative error.
- Dissimilar encoders and shaft speeds work together without error.
- Feedback and lead signals input to the MS196.
- The user enters the follower/master speed ratio and may change it on the fly.

MS196 Application Diagrams

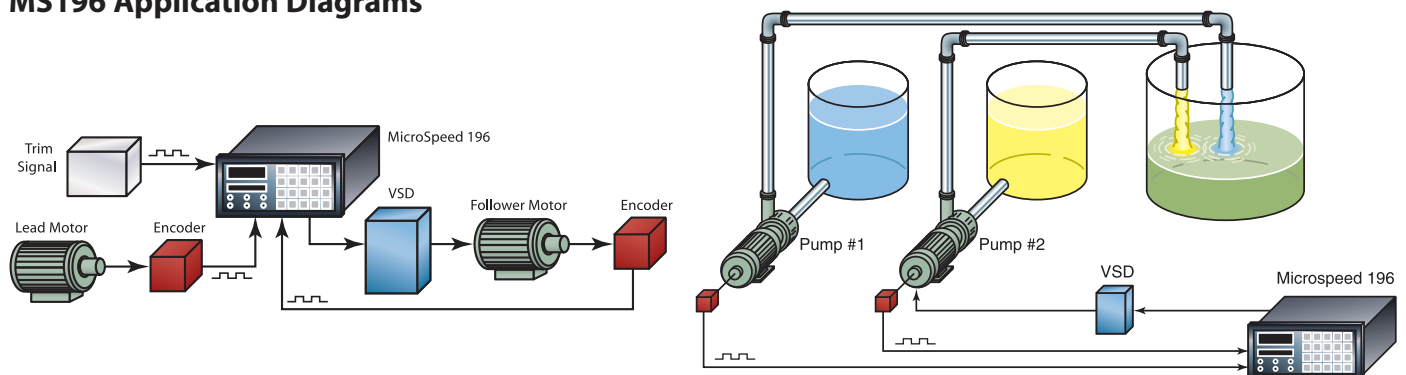

Typical Encoder and Index Device Wiring

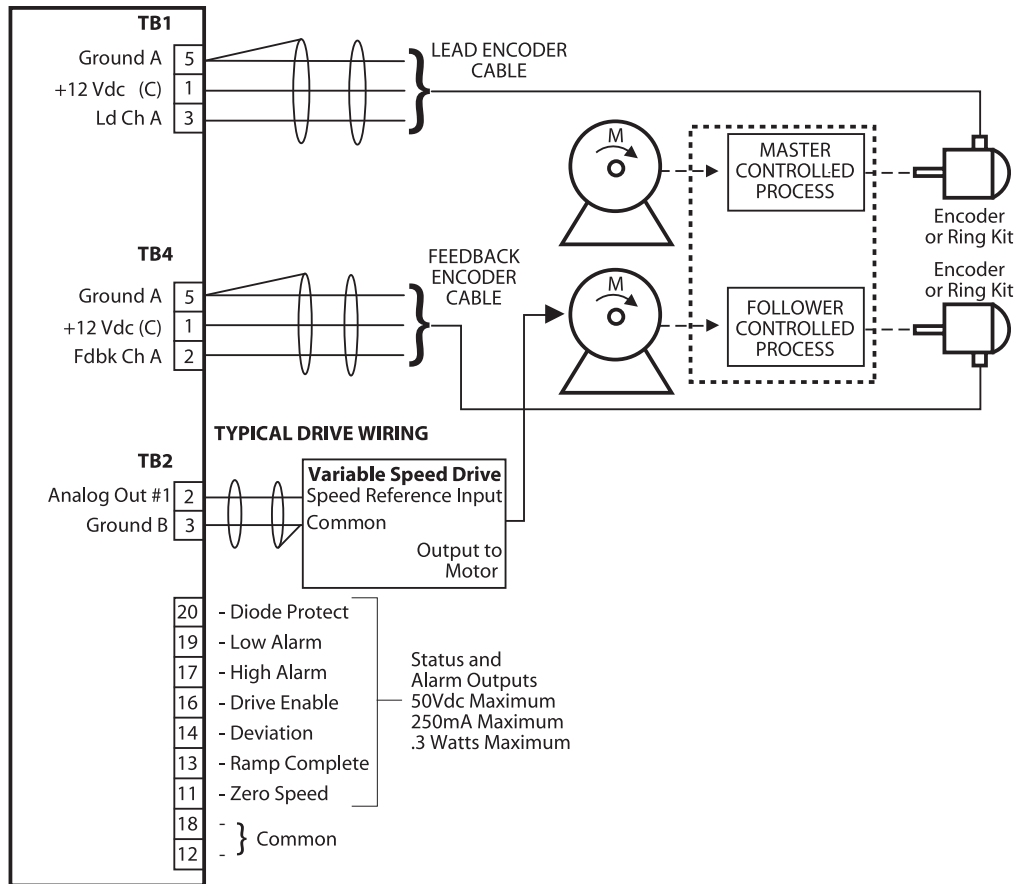

MS196 Specifications

Input Voltage

Power..... 115/230 Vac, 50/60 Hz

Sensor Inputs

Sensor Supply..... 12 Vdc @ 250 mA max
 Sensor Compatibility..... Single-ended NPN, PNP, Magnetic Pickup, Logic Level
 Trigger Levels 2 V (logic low), 3 V (logic high)
 Encoder type..... Square Sine
 Encoder Frequency..... 100 Hz - 40 KHz

Analog Outputs

Type..... Isolated, 0 ± 15 Vdc
 Resolution 12 bit D/A Converter

Transistor Outputs

Quantity..... 6
 Type NPN Open collector
 Rating 0.3 Watts (max), 50 Vdc (max)
 Assignable Functions..... Numerous alarms and indicators

Switch Inputs

Quantity..... 8
 Type Shorting (pull to ground)
 Assignable Functions..... Set point, mode, parameter & diagnostic selects; special functions

Serial Communications

RS422 Interface Standard, 300 to 19200 Baud,
 13 Character String, 1 Start, 8 Data, No Parity, 1 Stop

Operational

Accuracy..... Zero cumulative error (follower)
 0.01% of speed set point (master)
 Loop Response 10ms
 Operating Modes..... Ratio, follower, master
 Set Points 4 per operating mode

Mechanical/Environmental

Enclosure Material Cold rolled steel
 Key Pad..... Tactile feedback membrane, chemical resistant, splash-proof
 Operating Temperature 0° C to $+50^{\circ}$ C
 Humidity 0 to 90% non-condensing
 Panel Cutout 5.4" wide x 2.7" high x 7.2" deep
 Weight 6 lb

* Contact factory for higher temperature ranges.
 Specifications subject to change without notice.

DCS-910 Rev D



Gordy's Sensors

5772 Smaller Rd, Johnstown, OH 43031 Phone: (740) 967-2283 Fax: (740) 967-2855
 Website: www.gordyssensors.com or Email: sales@gordyssensors.com