

- 1. +24V
- 2. GND
- 3. PGND
- 4. DGND
- 5. RS485A
- 6. RS485B

Digital model sensing head terminal

Maintenance

Lens cleaning

Blow off particles by using clean compressed air. Gently brush the remaining debris away with a camel's hair brush. Carefully wipe the surface with a moist cotton swab or clean soft rag. The swab or rag may be moistened with water based glass cleaner.

Case cleaning

To clean the exterior housing, simply use soap and water or a mild commercial cleaner. Wipe with soft rag.

Warranty

Our products are warranted for one year on the condition of normal use and maintenance. We offer lifelong fee-based service when the products are over warranty period. Users should not take apart the instrument freely. If fail, please return to the company for service.

Optional parts

Air sweeper



Gordy's Sensors

5772 Smaller Rd, Johnstown, OH 43031 Phone: (740) 967-2283 Fax: (740) 967-2855
Website: www.gordyssensors.com or Email: sales@gordyssensors.com



GORDY'S SENSORS

Specializing in Sensors for the Steel Industry

Need help with your application or to place an order?
CALL : (740) 967-2283 FAX: (740) 967-2855

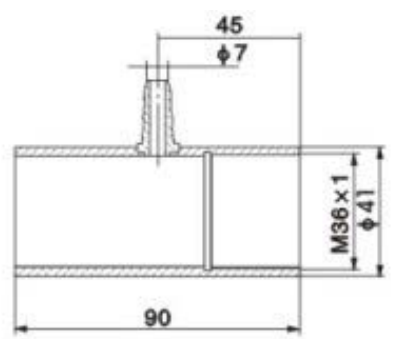

Water cooling

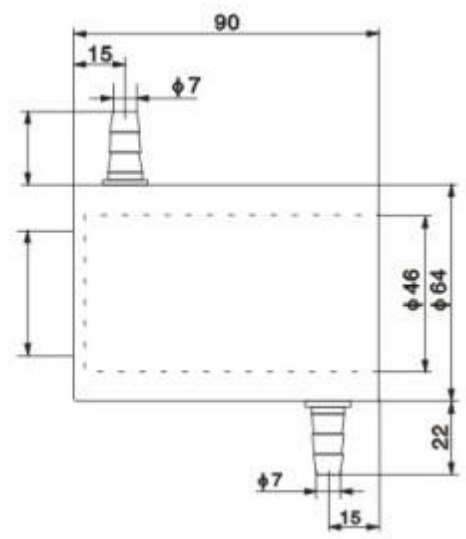

Laser Aimer

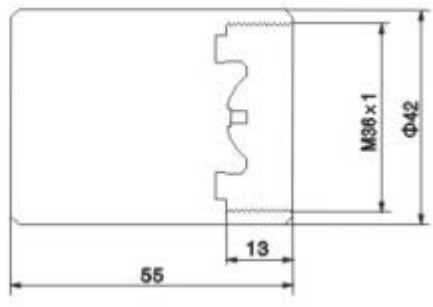

Gordy's Sensors

5772 Smaller Rd, Johnstown, OH 43031 Phone: (740) 967-2283 Fax: (740) 967-2855
Website: www.gordyssensors.com or Email: sales@gordyssensors.com