



8901 E. PLEASANT VALLEY ROAD
 INDEPENDENCE, OHIO 44131-5508
 TELEPHONE: (1) 216-642-1230 • FAX: (1) 216-642-6037
 E-MAIL: tachs@avtron.com • WEB: www.avtronencoders.com

Encoder Instructions

M6-4, M6-5, M6-6, M6-7

**EXPLOSION PROTECTED
HOLLOW SHAFT**

DESCRIPTION

The Avtron Model M6-4, M6-5, M6-6 and M6-7 are Hollow Shaft Incremental Encoders (also known as tachometers or pulse generators). They are similar to the model M4 Heavy Mill Duty rotary hollow shaft incremental encoders but utilize flameproof and increased safety construction. The M6 compliance with the Essential Health and Safety Requirements has been assured by compliance with EN60079-0, EN60079-1 and EN60079-7 (Certificate of Conformity No. DEMKO 02 ATEX 131477X) The M6 is certified for use in CAT 2 (Zone 1) Gas Group IIC potentially explosive atmospheres when marked with the code $\text{Ex II 2G Ex de IIC T4 (Tamb -20}^\circ\text{C to +80}^\circ\text{C)}$. Tamb -40°C also available (Special modification 001 or 005).

When mounted to a motor or machine, the M6 output is directly proportional to shaft position (pulse count) or speed (pulse rate). The M6 can be used for both control and instrumentation applications. The hollow shaft version of the model M6 eliminates shaft couplings, adapter flanges, or accessory mounting faces. The unit employs a hollow shaft and clamping collar to lock the encoder to the shaft. An anti-rotation bracket prevents rotation of the encoder while allowing for shaft end float.

The enclosures on all Model M6s are rated IP 66 to protect the internal components from the entry of dust and water. Additionally, the M6 uses magnetoresistive sensing technology, making the M6 ideal for demanding industrial environments.

All M6s can be equipped with one or two outputs. Each output is electrically independent and totally isolated.

The outputs can be wired as single ended single phase, single ended two phase (A,B), or differential (A Quad B). Output resolution is determined by the rotor's base PPR (pulses per revolution), times a sensor multiplier. The sensor module can provide: 1/2 the base PPR, the base PPR, or double the base PPR (see table). With two outputs, the same encoder can provide two different PPRs from a given rotor at the same time. Only one rotor per encoder is possible.

	AVAILABLE RESOLUTIONS		
	-48 OPTION	-51 OPTION	-60 OPTION
LOW	240	256	300
MEDIUM	480	512	600
HIGH	960	1024	1200

Example: an M6 could use a 1024 PPR sensor output on one side for feedback to a drive system, and simultaneously use a 256 PPR sensor on the other side for a process computer.

INSTALLATION CONSIDERATIONS

The M6 standard flexible anti-rotation bracket will tolerate ± 0.1 " of shaft end float. Consideration should be taken when positioning the encoder.

CAUTION

Be careful not to damage clamping fingers during handling. Do not tighten clamping collar before installation onto motor shaft. Damaging clamping fingers can affect the quality of installation.

M6 ENVIRONMENT

The M6 does not produce flammable gasses or dusts in normal operating modes. The M6 does not cause injury or harm when used in conjunction with the installation guide. The M6 does not produce ignition capable electrical sparks or arcs and has been designed not to produce potential ignition sources from electromagnetic, acoustic, optical or other energy sources. The M6 is not considered as a safety device and is not suitable for connection into a safety system.

The installer should refer to the latest edition of the following standards before installing or operating in a Hazardous Area:

EN 1127-1 Explosive Atmospheres - Explosion prevention and protection, basic concepts, and methodology.

EN 60079-14 Electrical apparatus for explosive gas atmospheres - Part 14: Electrical installations in hazardous areas (other than mines).

The M6 housing and shaft materials are listed in the specifications. These materials are not considered as able to trigger an explosion in normal operating modes and various fault modes in accordance with the requirements for Cat 2 equipment. These materials are not known to react with any explosive atmospheres to which the M6 may be subject. It is however the responsibility of the end user to ensure that the M6 is selected correctly for the potentially explosive atmosphere in which the equipment is to be put into service.

M6 PART NUMBERS AND AVAILABLE OPTIONS								
Model	Bore Size	Mounting Style	Line Driver	Left & Right Output Range	Base PPR	Marker	Connector	Modifications
M6-	0- Non-Standard 4- 1" 5- 1 1/8" 6- 2" 7- 2 3/8"	S- End of Shaft	1- 5 to 24 VDC 2- 5 to 18 VDC 3- 12 to 24 VDC	X- None L- Low Range (Base PPR x 1/2) M- Medium Range (Base PPR x 1) H- High Range (Base PPR x 2)	48- 480 51- 512 60- 600	Z- Marker -- None	T- Conduit Box, Terminal Block, 3/4" NPT W- Conduit Box, Terminal Block and Wire Gland	000- None 001- Low Temp (-40°C) 003- Torque Arm B28390 005- Low Temp (-40°C) & Torque Arm

INSTALLATION

Equipment needed for installation

Supplied:

- | | |
|---------------------------------------|----------------------------------|
| 1. M6 | 7. Nut, 1/4-20 |
| 2. Clamping Collar | 8. Washer, Flat 1/4 (2) |
| 3. Anti-rotation Bracket | 9. Washer, Lock, 1/4 |
| 4. Thread Locker (blue) | 10. Washer, Shoulder, |
| 5. Screw, Button Hd.,
3/8-16 x .50 | 11. Washer, Flat, Insulating (2) |
| 6. Screw, Socket cap 1/4-20 x .62 | 12. Anti Seize (copper) |

Not Supplied:

- 7/32" Hex wrench (T-handle style)
- 3/16" Hex wrench (T-handle style) (M6-4 & M6-5 only)
- 1/4" Hex wrench (T-handle style) (M6-6 & M6-7 only)

Clean machine shaft of any dirt and check for any burrs or damage.

The hollow shaft M6 is intended to be installed with a torsionally rigid flexible anti-rotation arm. See specifications for maximum shaft and bearing load ratings. The encoder should not be rigidly mounted.

Instructions for Installation of the Standard Flexible Anti-Rotation Bracket:

Install the anti-rotation bracket to the motor side of the M6 using two 3/8-16 screws and thread locker.

Remove screws from clamping collar, apply anti-seize compound supplied to the inside of the collar and thread locker supplied to the threads and reinstall. Place clamping collar loosely on the inboard end of the shaft. Carefully slide M6 onto the shaft. **DO NOT FORCE.** Encoder should slide on easily. After verifying M6 fit onto shaft, remove M6, apply anti seize compound (supplied) to shaft and re-install M6 (see shaft engagement). Tighten screws on clamping collar evenly until snug, then firmly tighten. **DO NOT USE A STANDARD RIGHT ANGLE WRENCH.** Use only a T-handle hex wrench or torque wrench with hex bit.

Secure free end anti-rotation bracket to frame. Use supplied insulating hardware if necessary as shown. Adapter kits are available for NEMA 56C and 8 1/2" mounting faces.

Optional torque arm kits are available (supplied with instructions).

Shaft Engagement For End-of-Shaft Mounting Applications:

See table on last page.

For shaft lengths greater than the maximum engagement allowed, end of shaft mounting may still be employed by locating the encoder away from the motor using a spacer between the motor and anti-rotation bracket.

Corrective Action for Excess Housing Movement (Wobble)

The hollow shaft M6 design eliminates the potential for bearing and coupling failures from misalignment, however, excessive housing movement (wobble) may cause undesirable vibrations. The higher the RPM, the more severe the vibration will be from housing movement. In a typical installation a housing movement of 0.007" TIR or less (as measured at the outside diameter of the main encoder body) will not have an adverse effect. If excessive housing movement is detected in the installation:

1. Check the shaft the M6 is mounted on for excessive shaft runout. NEMA MG1 calls for 0.002" TIR or less.
2. Verify that the M6 engagement with the motor shaft conforms to the engagement rules on page 4. In general, maximizing engagement will minimize housing movement.
3. Verify that the mounting shaft diameters conform to the rules on page 4. Excessive housing movement occurs when the clearance between the motor shaft and pulse generator shaft allows the two center lines to miss match.
4. Loosen the clamping collar and rotate the motor shaft 180° within the M6 hollow shaft sleeve.
5. Make sure the clamping collar is tightened equally on both sides.

SPECIFICATIONS

ELECTRICAL

- A. Operating Power (Vin)
 - 1. Volts..... See Line Driver Options
 - 2. Current..... 120mA, no load
- B. Output Format
 - 1. 2Ø & Comp (A,Ā, B,B)
 - 2. Marker 1/Rev (Z,Z̄)
- C. Signal Type Incremental, Square Wave, 50 ±10% Duty Cycle
- D. Direction Sensing ØA leads ØB for CW rotation as viewed from the back of the tach looking at the non-drive end of the motor.
- E. Transition Sep. 15% minimum
- F. Frequency Range..... 0 to 150,000 Hz.
- G. PPR..... 240, 256, 300, 480, 512, 600, 960, 1024, 1200
- H. See Line Driver Options

MECHANICAL

- A. Shaft Inertia..... 0.8 to .23 oz. In. sec.²
- B. Acceleration..... 5,000 RPM/Sec. Maximum
- C. Starting Torque 1.5 to 20 Oz. In.
- D. Speed 5,000 RPM Max. (M6-4,-5); 3600 RPM Max. (M6-6,-7)
- E. Weight 18 lbs. Maximum
- F. Shaft Diameter
 - Tolerance..... See drawing on page 4.
- G. Shaft Engagement See drawing on page 4.
- H. Bearing Protection: Shaft seal & double bearing seal.
- I. Bearing Life with No Additional Loading: 6.1 x 10⁶ Revolutions
- J. Maximum Additional Bearing Load:
 - 1. -1 (5/8"): 5 pounds axial or 20 pounds radial
 - 2. -4 & -5 (1" & 1 1/8"): 10 pounds axial or 30 pounds radial
 - 3. -6 (2"): 25 pounds axial or 75 pounds radial
 - 4. -7 (2 3/8"): 30 pounds axial or 90 pounds radial
- K. Shaft Material: Black Oxide treated steel.
- L. Housing Material: Cast aluminum with Polane S Plus polyurethane enamel finish.

ENVIRONMENTAL

- A. Enclosure Rating: IP66
- B. Operating Temperature: 80°C to -40°C (-40°C optional, -20°C standard)
- C. Hazardous Locations: Ex de IIC T4 (Tamb -20°C to +80°C Standard, -40°C to +80°C Optional use Modification "001" or "005")

OUTPUT TERMINATIONS

Terminal Block: EEx e II compression type. Accepts AWG 14 (2.08mm²) to AWG 20 (.52mm²) stranded wire. Housing available with 3/4 NPT or optional armored cable gland available (maximum ambient temperature with gland +60°C allowing for 20°C rise in housing.)

LINE DRIVER OPTIONS

	Output Options		
	1	2	3
Voltage Input (Vin)	5-24 VDC	5-18 VDC	12-24 VDC
Output High (Volts)	(Vin) -2 (typ)	(Vin) -1 (typ)	330 ohm pull up
Output High (milliamps)	80 (max.)	80 (avg.), 1500 (peak)	330 ohm pull up
Output Low (Volts)	0.5 (typ)	0.5 (typ)	1 (max.)
Output Low (milliamps)	80 (max.)	80 (avg.), 1500 (peak)	50 (avg.)
Protection	Reverse Voltage, Transient, Short Circuit (high & low)	Reverse Voltage, Transient, Short Circuit (none)	Reverse Voltage, Transient, Short Circuit (low)
Maximum Cable Drive(Feet)	1000 ft. @ 5 V 500 ft. @ 12 V 200 ft. @ 24 V	2000 ft.	1000 ft.

6. Move the split in the clamping collar over a solid portion of the M6 shaft.

If excessive housing movement still exists after the above steps, it may be necessary to physically bias the attitude of the encoder on the motor shaft while the clamping collar is being tightened. Either by eye or using dial indicators, note the position around the outside diameter of the encoder that is most out of position from true while turning the motor shaft slowly. With the motor shaft no longer turning, loosen the clamping collar. While applying moderate force by hand against the outside diameter of the encoder on the side opposite where the out of true position was observed, retighten the clamping collar. Several iterations may be necessary if the first attempt under or over compensates. This method may be used to help compensate for undersized shafts, shaft runout, bent clamping fingers, and other problems.

WIRING INSTRUCTIONS

The M6 can be wired for single phase, two-phase, with or without complements, with or without markers. See wiring diagrams below.

CAUTION

Do not wire the M6 Encoder while energized. Doing so may damage the encoder, and/or cause risk of fire or explosion.

For bidirectional operation of the encoder, proper phasing of the two output channels is important. Phase A channel leads phase B channel for clockwise shaft rotation as viewed from the anti-drive or accessory end of the motor (M6 mounting end).

CORRECTIVE ACTION FOR PHASE REVERSAL

- 1) **Remove Power.**
- 2) Exchange wires on cable, either at encoder cable end, or at speed controller end (but not both).
 - a) **Single Ended 2 Phase Wiring** (see wiring diagram) Exchange A and B at the use end of the wires.
 - b) **Differential 2 Phase Wiring** (see wiring diagram) Exchange **either** A with \bar{A} in the phase A pair **OR** B with \bar{B} in the phase B pair but **NOT** both.
- 3) Apply Power.
- 4) Verify encoder feedback is correct, using hand rotation of shaft, or jog mode of the speed controller.

Refer to the system drawing for specific cable requirements where applicable.

Physical properties of cable such as abrasion, tensile strength, solvents, marine applications, etc., are dictated by the specific application. Requirements for hazardous locations are dictated by the relevant codes. General electrical requirements are: stranded copper, 20 AWG (.52mm²) thru 14 AWG (2.08mm²) each wire pair individually shielded with braid or foil with drain wire, 0.05 uF maximum total mutual or direct capacitance, outer sheath insulator, 2,000 ft. max. (see line driver specifications.) Temperature ratings of wire and wire glands should be 20°C over the maximum expected ambient or motor temperature to allow for temperature rise in the M6 itself.

WIRING DIAGRAMS

DIFFERENTIAL APPLICATIONS

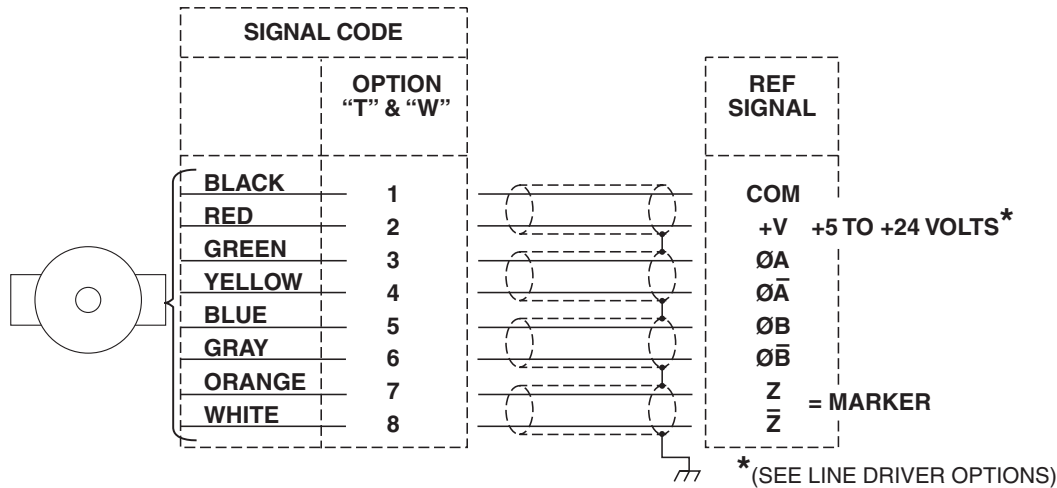

SINGLE ENDED SINGLE PHASE APPLICATIONS

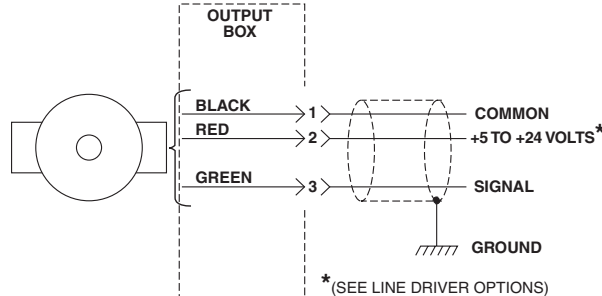

SINGLE ENDED TWO PHASE APPLICATIONS

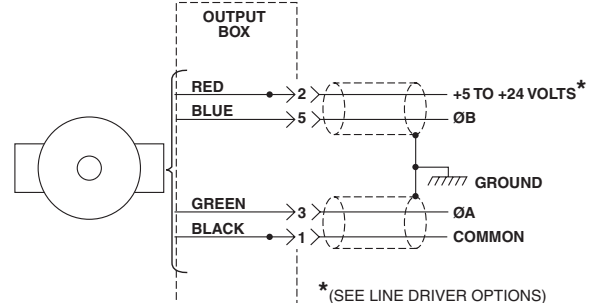

NOTE: Avtron standard warranty applies. Copies available upon request. Specifications subject to change without notice.

TYPICAL WIRE:
18 AWG (.82mm²), multiple pair,
individually shielded.

MAINTENANCE

CAUTION

Do not open the M6 housing. Doing so will void the warranty and may cause the risk of fire or explosion.

There are no field replaceable parts in an M6. The unit should be returned to the factory for all repairs.

Build up of large amounts of contamination are to be avoided, therefore periodic external cleaning is recommended.

The condition of the bearings is important to the safety of the explosion-proof housing. The bearing manufacturer's rated life (see specifications) can be adversely affected by application specific conditions. If the unit shows signs of bearing wear indicated by noise or degradation of the electrical signal output, it should be returned to the factory for repair.

OUTLINE DRAWING

INBOARD VIEW

ADJUSTABLE ANTI-ROTATION ARM ASSY
90°
MOUNTING BRACKET
3/8-16 X .50 BUTTON HD SCREWS
5.12
6.44 [163.63]
5.32 [135.13]
OPTIONAL MOUNTING POSITIONS
5.44 [138.23]
OPTION "W" TERMINAL BLOCK WITH ARMORED CABLE GLAND
NOTE: CABLE GLAND Tamb (-60°C to 80°C) MUST BE DERATED FOR TEMPERATURE RISE IN ENCODER.

MOTOR VIEW

NOTE: FOR MAXIMUM STABILITY AND OPERATING CONDITIONS, MOUNT THE ANTI-ROTATION ARM ASSY WITH THE M6 TACH AS CLOSE AS POSSIBLE TO THE MOTOR HOUSING, UTILIZING THE ABOVE MOUNTING PROCEDURE.
M7 Encoder
MOTOR

SHAFT OPTION	DIMENSION		
	AA MOTOR SHAFT OD	BB LENGTH	CC MIN/MAX ENGAGEMENT
4	1.0000/0.9995 [25.4000/25.3873]	4.30 [109.22]	2.000/2.620 [50.800/66.548]
5	1.1250/1.1245 [28.5750/28.5623]	4.30 [109.22]	2.000/2.620 [50.800/66.548]
6	2.0000/1.9990 [50.8000/50.7746]	4.48 [113.79]	2.250/2.750 [57.150/69.850]
7	2.3750/2.3740 [60.3250/60.2996]	4.58 [116.33]	2.500/3.000 [63.500/76.200]

2.75
2.81
AVTRON
PULSE GENERATOR
Type Option Code Rev Ser.No. Date Mfg
PPR VDC
Imax= 160mA, Pmax= 4.48W Ea Output
Ex de IIC T4 (Tamb to +80°C)
CE 0539 II 2G
Cert No. DEMKO 02 ATEX 131477X IP66
WARNING: DO NOT OPEN IN A FLAMMABLE ATMOSPHERE OR WHEN ENERGIZED

1/4-20 x 0.62 [15.87] SOCKET HD CAP SCREW WITH INSULATING WASHERS SUPPLIED
3.77 [95.88] 0.56 [14.23]
INTERNAL GROUNDING LUG
7.19 [182.63] DIA
EXTERNAL GROUNDING LUG
3/4" NPT
ANTI-ROTATION BRACKET
SHAFT COLLAR
SHAFT BORE
4.45 [113.03]
OPTION "T" TERMINAL BLOCK

Tamb -20°C to +80°C standard, optional Tamb -40°C to +80°C available with special option codes 001 and 005.

4 – IDENTIFICATION LABEL: SEE ABOVE
3 – DIMENSIONS IN PARENTHESIS ARE MILLIMETERS
2 – ALL DIMENSIONS ARE APPROX.
1 – WEIGHT: 18 LBS. MAX.
NOTES:
* "VDC" to be "5-18" or "5-24" or "12-24"

Features and specifications subject to change without notice. Avtron standard warranty applies. All dimensions are in inches [mm] approx.

EU DECLARATION OF CONFORMITY: The Model M6 Encoder has been assessed and type tested against the following Harmonized European Standards: EN 50081-1:1992, EN 50082-1:1998. The Model M6 has been found to be compliant with the requirements of EU Directive 89/336/EEC provided that the following conditions are met: The electrical supply to the M6 must be within specified limits. The electrical supply must offer suitable protection from voltage surges unless the application does not require such protection. On behalf of Avtron: Stephen L D'Henin, Certification Manager, Epsilon Certification Service.

These instructions have been reviewed and the product evaluated as suitable for our application.

Company Name _____

Authorized Company Representative _____

Title _____ Date _____



Gordy's Sensors

5772 Smaller Rd, Johnstown, OH 43031 Phone: (740) 967-2283 Fax: (740) 967-2855
Website: www.gordysensors.com or Email: sales@gordysensors.com