



# 950MD Mill-Duty Housing

## Series 950MD Gemco Mill-Duty Housing

### Series 950MD Mill-Duty Housing

The Series 950MD is designed for applications where mounting a stand-alone magnetostrictive linear displacement transducer is prohibitive due to potential physical damage, environmental considerations or mounting limitations. The Mill-Duty Housing is designed to eliminate all of the above problems by protecting an LDT from physical and environmental damage, such as temperature or corrosives, and offers a simple two-point mounting scheme that can compensate for lateral and horizontal play in the machine while in operation. The Series 950MD was originally designed for use in steel mill applications, but has proven reliable in many applications where ruggedness, environmental protection and ease of mounting are required. These applications include:

**Steel Mills** - Tundish car (Tundish height), turret height (caster), hydraulic coil cars, torch cutoff machine (torch head monitoring), furnace tilt (electric arc furnace), side guide positioning, ladle slide gate positioning, louver position, etc.

**Injection Molding** - Proven effective in monitoring/controlling the position of the clamp and/or shot cylinder. The two-point connection allows for simple retrofit.

**Hydraulic Servo Applications** - Ideal for paralleling hydraulic cylinders, including new applications and retrofits. The major advantage in using mill duty housings versus cylinder mounted LDTs is that the cylinder fluid flow is not compromised. If an LDT fails within a cylinder, it cannot be repaired/replaced without having to drain the fluid from the cylinder. Also, some cylinders may be difficult to remove once installed, thus inhibiting the removal of the LDT. The Mill-Duty Housing can be removed without affecting the cylinder.

The Series 950MD consists of an all stainless steel body. The head assembly is removable to allow a magnetostrictive linear displacement transducer to screw in. The head also contains a 1/2" conduit port for customer wiring to the LDT and two air purge ports for air cooling (if necessary).

The actuator contains a 1/2" spherical rod end with approximately 1" of adjustment (length). This spherical rod end allows mechanical movement in a horizontal and/or vertical motion to compensate for any mechanical slop or misalignment between the housing and machine.



A rear trunnion mount is provided for mounting either directly in front of the head assembly or on the rear of the head. An optional 3/4" spherical rod end can be supplied on the rear of the unit (see drawing for details).

The actuator rod is supported by two bearings within the guide tube. The front piston bearing contains a wiper assembly to keep contaminants from entering the guide tube. The rear, or movable, bearing assembly is manufactured from Rulon. This high-temperature polymer material provides low wear and smooth operation.

The transducer magnet is mounted within the rear bearing assembly. The magnet is a 1" O.D. style. The magnet is positioned 2" from the end of the transducer hex when the actuator is fully retracted and 5" from the end of the transducer guide tube when the actuator is fully extended.

The Series 950MD is designed to incorporate an LDT which has a minimum 2" null zone and 5" dead zone. The Series 951 LDT has a minimum 1.5" null zone and 2.25" dead zone standard. When specifying a Series 951 LDT

Accessories



## 950MD Mill-Duty Housing

to be used in a Mill-Duty Housing, you must specify a 2" null zone and 5" dead zone minimum to ensure mechanical and electrical compatibility.

Due to the fact that the standard Mill-Duty Housing has a mechanical stroke identical to the LDT active stroke, no physical overstroke exists. If it is possible that the machine being coupled to can extend/retract beyond the stroke supplied, damage to the Mill-Duty Housing and possibly to the machine might occur. To compensate for this we call out fully retracted/fully extended overstroke dimensions for the Mill-Duty Housing. These values are essentially the additional stroke length added to the Mill-Duty Housing. The reason they are called out separately is to alert the user that when entering these areas, they are out of the LDTs active stroke area. If an extended overstroke is specified, the LDT must be ordered with a dead band of 5" + X (extended stroke value). If a retracted overstroke is specified, the LDT must be specified with a null value of 2" + Y (retract overstroke value).

The Mill-Duty Housing offers either a conduit entrance only for hard wiring directly to the LDT within the head or an external MS style connector and mate. The connector attaches to the LDT via a small pigtail connector within the head.

**Optional Items** - The standard Mill-Duty Housing includes the complete housing assembly with provisions to accept an LDT and all bolts, nuts and mounting hardware required for a complete installation. There are also several optional items available.

**Vortex Air Cooler** - The standard Series 950MD is equipped with air purge ports. In many cases, running clean shop air through the head is sufficient to cool the electronics. For severe temperature applications a Vortex Air Cooler may be desired. A Vortex Air Cooler accepts standard shop air (80 - 100 PSIG). The air is ejected through a generator in a Vortex spin chamber where the air stream revolves in a tube at up to 1,000,000 RPM. In simplest terms the inner stream gives off energy in the form of heat to the outer stream and the inner stream exits the opposite end as hot air. The Vortex cooler is capable of generating air flows as cold as -40°F.

**Protective Boots** - To give added protection to the actuator rod, protective boots are available. These boots attach between the end of the mill duty guide tube and the end of the actuator rod assembly. The boots are

offered in neoprene-coated nylon for most standard applications. They offer -60°F to 250°F operating range with resistance to water and oil. Also, silicone coated fiber glass offers high temperature resistance from -100°F to 550°F; Teflon-coated fiber glass offers -100°F to 500°F operating range with a high degree of corrosion resistance.

**Water-Cooled Head Assemblies** - In applications where extreme temperatures are present and air cooling is not appropriate, water-cooled head assemblies are available. Cooling jackets within the head assembly allow water to flow around the electronics.

**Rear Mount Spherical Rod Ends** - In applications where two spherical rod ends are required, rear mount spherical rod ends are available. The 3/4" rear rod end attaches to a threaded bolt extending from the rear of the head.



# 950MD Mill-Duty Housing

## Part Numbering

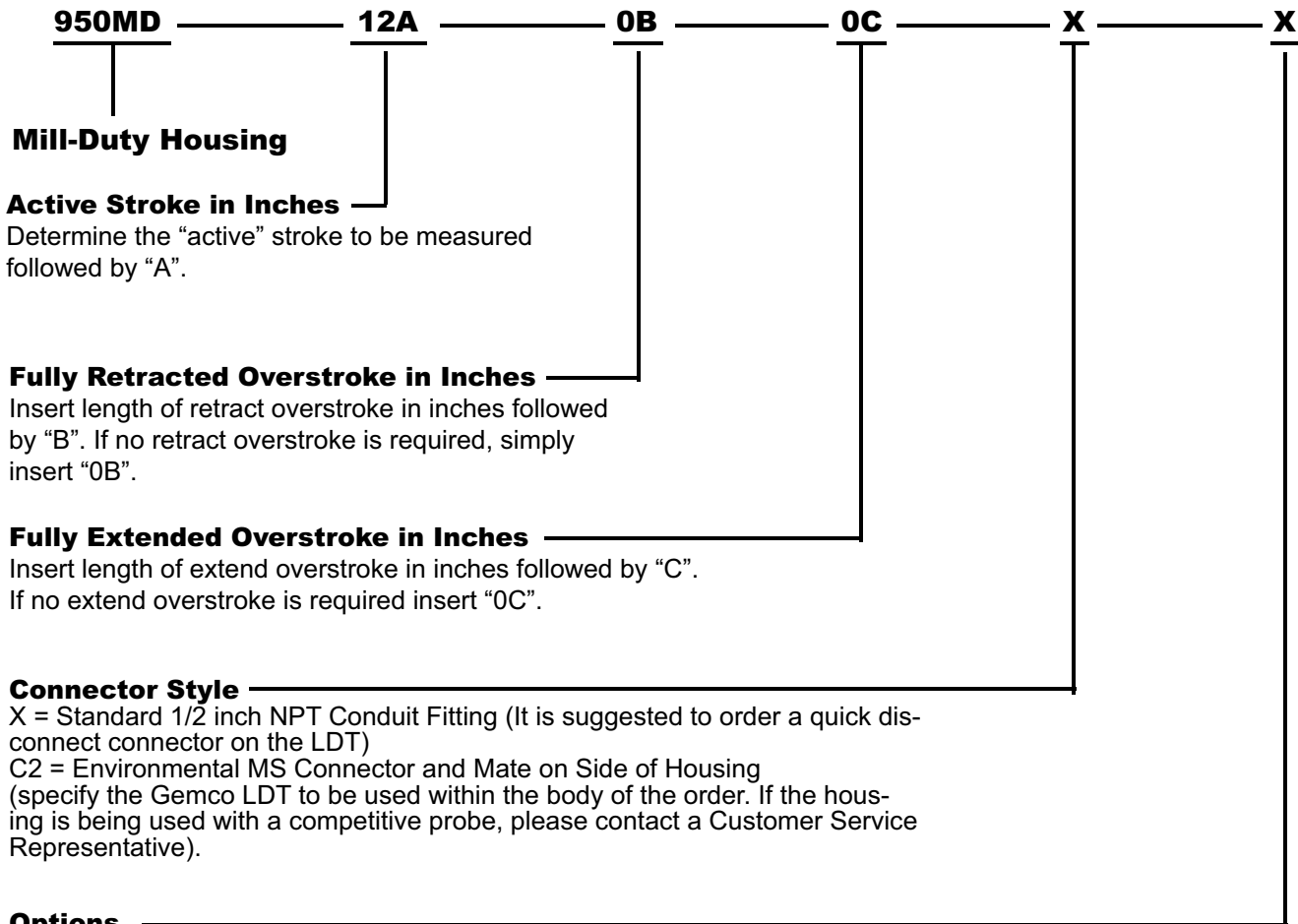

### Options

- X = None
- V = Vortex Air Cooler
- B1 = Protective Boot - Neoprene Coated Nylon (-60F to +250F )
- B2 = Protective Boot - Silicone Coated Fiber Glass (-100F to +550F )
- B3 = Protective Boot - Teflon Coated Fiber Glass (-100F to +500F )
- R = Rear Mount Spherical Rod End 3/4"
- F = Front Mount Spherical Rod End 3/4"

**Note 1:** Guide tube support brackets are supplied as standard for strokes of 72" or greater. **Note 2:** Special high temperature, abrasion resistant and oil resistant cables are available. Consult your Customer Service Representative.

Accessories

Accessories	
Item	Part Number
Vortex Cooler	04578009
Muffler for Cooler	04578010
Replacement 1/2" Spherical Rod End	04570140
Guide Tube Support Bracket (See note 1)	C0903400
Replacement (Male Connector) for Option "C2" Connector	04521407
Female Mating Connector for Option "C2" Connector	04521372

950MD Compatibility Guide	
940	Yes
950IS	Consult Factory
951	Yes (Must be ordered w/2" null & 5" dead zone)
952	Yes (Must be ordered w/2" null & 5" dead zone)
955	See 956 Section
7330	Consult Factory

## Standard 950MD

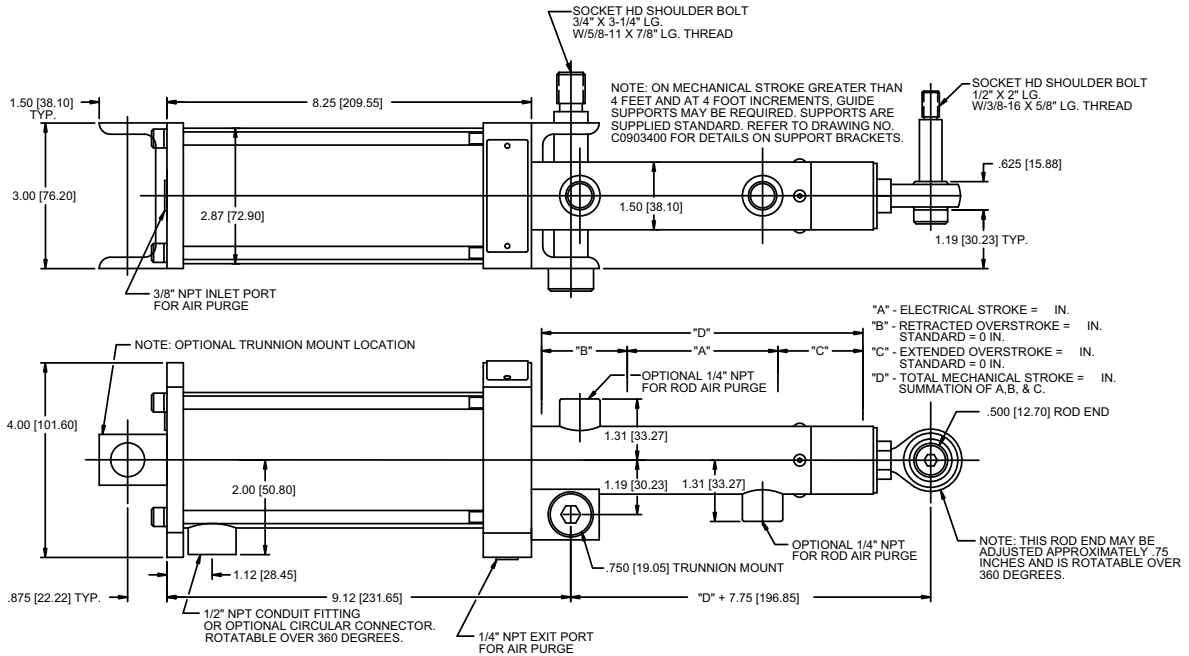

- NOTES: UNLESS OTHERWISE SPECIFIED  
1. DIMENSIONS IN BRACKETS [mm] ARE IN MILLIMETERS.  
2. FOR LDT OUTPUT SIGNAL CHARACTERISTICS IN THE OVERSTROKE ZONES, SEE APPROPRIATE LDT CATALOG SECTION.

## Mill-Duty with Rear Mount Spherical Rod End

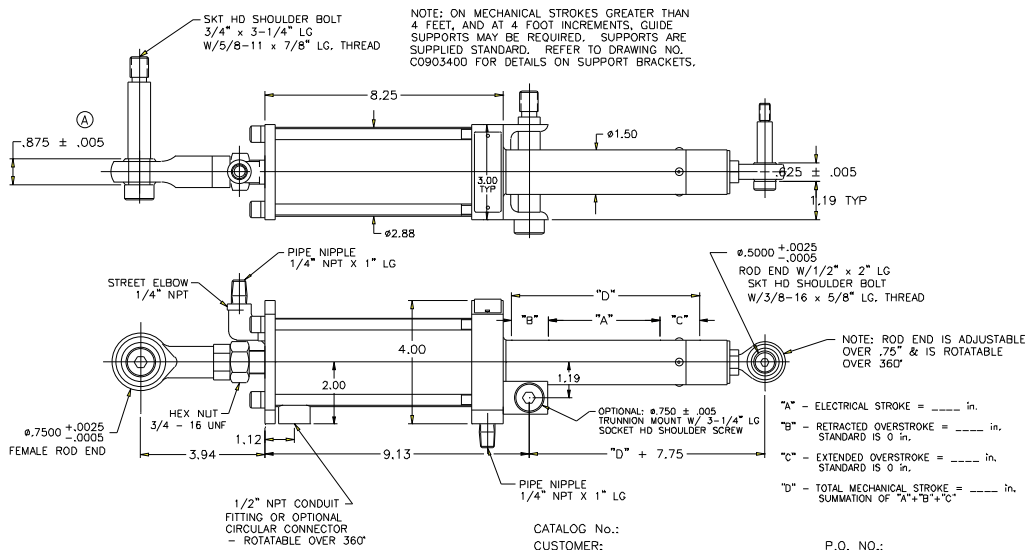

NOTE: FOR LDT OUTPUT SIGNAL CHARACTERISTICS IN THE OVERSTROKE ZONES, SEE APPROPRIATE LDT CATALOG