



foto-captor

IR-Light Barrier System

Transmitter: Type 6411 L

Receiver: Type 6403.43 / FOC 1042 / 1001 HSSL

Technical Documentation

weber

Sensors GmbH Strohdeich 32 D-25377 Kollmar Tel.: +49 4128-591 Fax: -593

Member of the captor Group

eMail: info@captor.de • www.captor.com

foto - captor IR-Light Barrier System



consisting of: Transmitter Type 6411 L
Receiver Type 6403.43 / FOC 1042 / 1001 HSSL

Technical Data

1.0 System General

Distance transmitter - receiver	max. 20 m
Ambient temperature	-20 °C...+70 °C
Construction	all parts and components fully encapsulated
Shock and vibration	in accordance with DIN 57411
Protection standard	IP 65 / DIN 40050

2.0 Transmitter Type 6411 L

Housing material	stainless steel WN 1.4541
Housing dimensions	see drawing no. 768932-2.KAT, REV:AA
Air purge	for ½ " hose connection
Mass for standard housing with air purge	1,9 kg
Connection cable	3 x 0.75 mm ² (with protection earth)
Supply voltage	24 V DC
Supply voltage tolerance	+10% / -15%
Current consumption	100 mA
Display, power supply	yellow LED
IR-radiation	pulsed
Transmission beam angle	1°

3.0 Receiver

3.1 Elektronic unit Type 6403.43

Housing material	Aluminium chromated
Housing dimensions	see drawing no. 768932-1.KAT, REV:AB
Mass	700 g
Electrical connection	Socket 6-pin (Harting)
Supply voltage	24 V DC
Supply voltage tolerance	+10% / -15%
Current consumption	approx. 15 mA
Function indication	green LED
Electrical output	optocoupler output
Load current	max. 30 V / 50 mA (R _i = 240 Ω)
Output function	n.o., optocoupler inactivated without IR-detection

weber

Sensors GmbH Strohdreich 32 D-25377 Kollmar Tel.:+49 4128-591 Fax:-593

REV:AA / 30.10.96
sgd. Wip. / RH

Page 1/3

foto - captor IR-Light Barrier System



3.0 Receiver

3.2 Fibre Optic Cable (FOC) Type 1042

Length	2m
Metal end sleeves	stainless steel, WN 1.4301
Flexible metallic hose	stainless steel, WN 1.4301
Ambient temperature	max. 400 °C
Dimensions	see drawing no. 23245.KAT, REV:AD
Mass	100g

3.3 Lens Type 1001 HSL

Housing material	stainless steel, WN 1.4541
Housing dimensions	see drawing no.765133.KAT, REV:AB
Air purge	for ½ " hose connection
Mass	1,1 kg
Viewing angle	1 °
Ambient temperature	max. 200 °C

weber

Sensors GmbH Strohdreich 32 D-25377 Kollmar Tel.:+49 4128-591 Fax:-593

REV: AB / 11.12.96
sgd. Wip. / RH

Page 2/3

foto - captor IR-Light Barrier System



4.0 Connection Diagrams

Transmitter Type 6411 L

Supply voltage
24 V DC

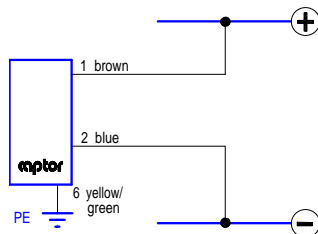

Receiver Type 6403.43

Supply voltage 24 V DC
Optocoupler output

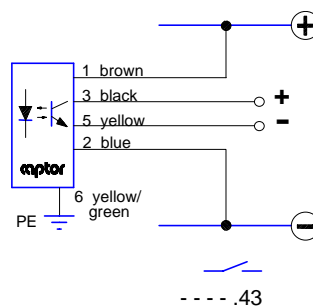

5.0. Cable Coupling, 6-pins (Harting)

- Ship with accessory of the receiver type 6403.43

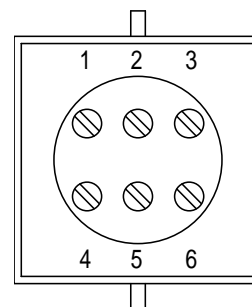
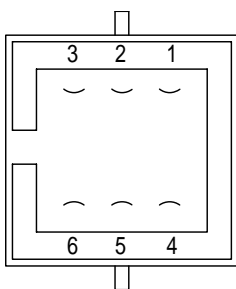

weber

Sensors GmbH Strohdreich 32 D-25377 Kollmar Tel.:+49 4128-591 Fax:-593

REV: AA / 30.10.96
sgd.: Wip. / RH

Page 3/3

foto-captor Light Barrier System



consisting of: Transmitter Type 6411 L
Receiver Type 6403.43 / FOC 1042 / 1001 HSLL

Installation Instructions

Please read carefully: No liability can be accepted for damage caused by improper use of the captor.

1.0 Mounting

- a. Install the transmitter and receiver so that they face each other.
For best mounting and alignment the special swivel stands should be used. They can be ordered separately.
When choosing the mounting position and installing the units, ensure that the units are
- * on a fixed and stable surface
 - * in a vibration-free place
 - * protected against unintentional / accidental shifting of the alignment
 - * protected against dirt accumulation
 - * protected against ambient and radiation temperatures above 75°C.
- b. The optimum power transfer function of the IR-Light Barrier System can only be reached with clean lenses.
The air purge facility in front of the lens helps to maintain this.

2.0 Electrical connection:

Connect the cable of the transmitter according to the connection diagram.

Supply:	brown	(1)	: Supply voltage +24 V DC (tolerance +10% / -15%)
	blue	(2)	: Supply voltage ground
	yellow / green		: Protective ground

For the receiver the supply output cable on customer site has to be connected to the included female plug as follows:

brown	(1)	: Supply voltage +24 VDC (tolerance +10%...-15%)
black	(3)	: output (+)
yellow	(5)	: output (-)
blue	(2)	: Supply voltage ground
yellow /green	(6)	: Protective ground

The optocoupler output is activated when receiving the IR-beam (normally open).
The max. optocoupler load is 30 V /50 mA ($R_i=240 \Omega$).

3.0 Power Supply

Switch on the power supply.
The yellow LED of the transmitter should be on.
The green LED of the receiver should be off (no IR detection).

4.0 Alignment

Pivot the transmitter and the receiver alternately in the vertical and horizontal axes until the IR-beam points to the centre of the receiver. The green LED on the receiver should be illuminated.

weber

Sensors GmbH Strohdreich 32 D-25377 Kollmar Tel.:+49 4128-591 Fax:-593

REV:AA / 30.10.96
sgd.: Wip. / RH

Page 1/1