

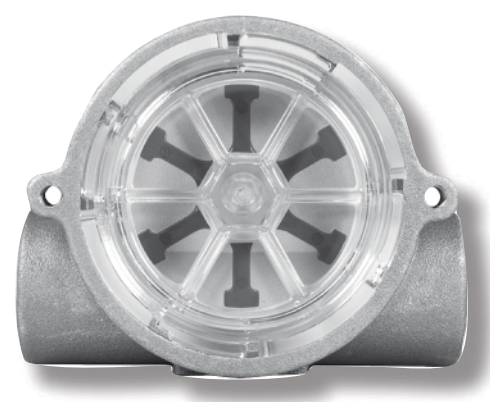

Introducing the TDFS Series Flow Switch.



SERIES: TDFS

APPLICATIONS

- Semiconductor Processing Equipment
- Lasers
- Medical Equipment
- X-Ray and Other High Power Tubes
- Robotic Welding Equipment

DESCRIPTION

TDFS Switches build an extra level of reliability and protection into your equipment. By principle of operation, the rotor cannot be deceived into indicating a positive flow situation when no flow actually exists. Once set to a desired actuation point, it will switch to a "no-flow" condition should the rotor stop for any reason.

DIMENSIONS

Polypropylene Bodies

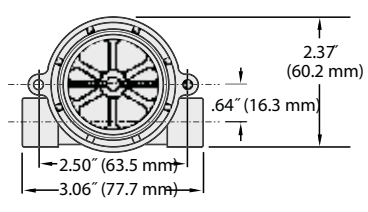

Brass and Stainless Steel Bodies - .25" and .50" Port

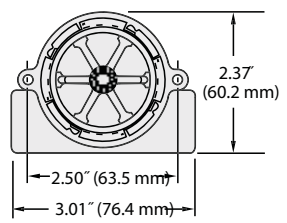

VDC

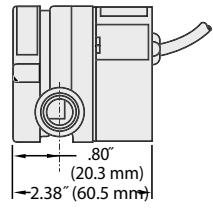

VAC

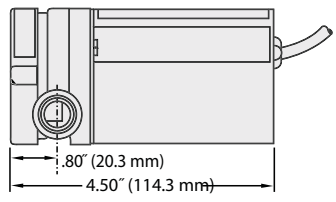

VDC

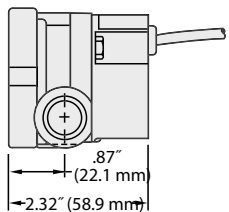

VAC

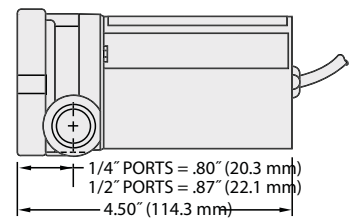



DIMENSIONS

Brass and Stainless Steel Bodies - .75" and 1.00" Port

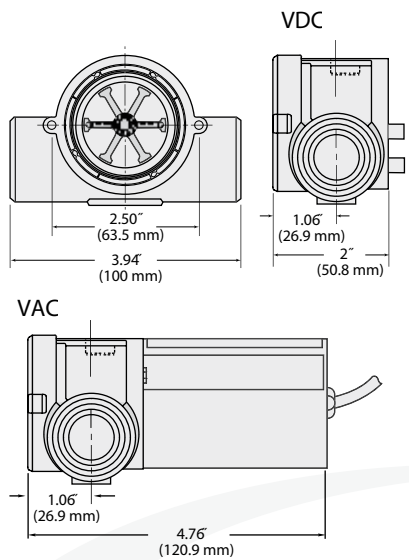

SPECIFICATIONS

Wetted Materials
 Body

Rotor Pin
 Rotor
 Lens

O-Ring

Low Flow Adaptor

Operating Pressure, Maximum

Brass or Stainless Steel Body

Polypropylene Body

Operating Temperature,

Brass or Stainless Steel Body

Polypropylene Body

Electronics

Viscosity, Maximum

Input Power

Relay Contact Ratings

Current Consumption

24 VDC

115 VAC

Repeatability

Set Point Accuracy (Factory Set) ± 5%

Set Point Differential

Electrical Termination

Brass, 316 Stainless Steel or Polypropylene
 (Hydrolytically Stable, Glass Reinforced)

Ceramic

PPS Composite, Black

Polysulfone

Viton® (Alloy Bodies); Buna N (Polypropylene Body)

Glass Reinforced Polypropylene

200 PSIG @ 70°F, 100 PSIG Max. @ 212°F 1

100 PSIG @ 70°F, 40 PSI Max. @ 180°F

-20°F to 212°F (-29°C to 100°C)

-20°F to 180°F (-29°C to 82°C)

150°F (65°C) Ambient

200 SSU

24 VDC or 115 VAC

(SPDT) 1 Amp, 24 VDC Resistive; 0.3 Amp, 110 VAC

No Load Load (Relay Energized)

20mA 35mA

45mA 95mA

2% Maximum Deviation

15% Maximum

20 AWG PVC-Jacketed, 24" Cable. Color Codes:

Red = +VAC/VDC, Black = Ground,

White = N.O. Contact, Brown = N.C. Contact,

Green = Common



CALLIBRATION

Switch Set Point Calibration With LED Signal:

With the unit installed in the line and power supplied, complete the following steps to calibrate switch actuation point with proper flow rate. A small flat-blade screwdriver is the only tool required.

1. Adjust liquid flow in the line to the rate at which switch actuation is desired.
2. Insert screwdriver into opening on backside of housing and fit blade into the potentiometer adjustment screw inside.
3. If LED is not illuminated, slowly turn screwdriver counterclockwise and stop as soon as LED illuminates.
4. If LED is illuminated, turn screwdriver clockwise until LED light goes out. Then, slowly turn screwdriver counterclockwise and stop as soon as LED illuminates.

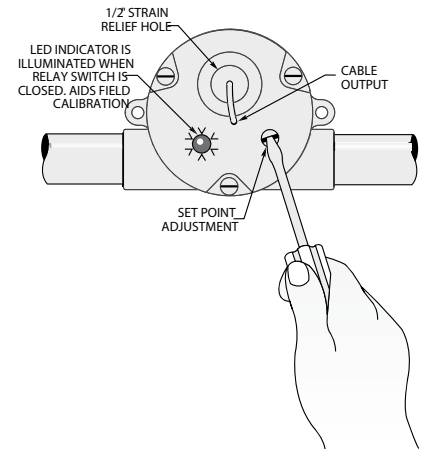

High Resolution Black Rotor
 PPS composite. Each of the six rotor arms is magnetized. A PTFE load bushing ensures long life.



ORDERING

Specify Part Number based on desired body material, port size and input power rating.

Body Material	Port Size NPT	Flow Ranges – GPM		Input Power	Part Number
		Low Range*	Standard Range		
Polypropylene	.25"	0.1 to 1.0	0.5 to 5.0	24 VDC	TDFS01
				115 VAC	TDFS02
	.50"	1.5 to 12.0	4.0 to 20.0	24 VDC	TDFS03
				115 VAC	TDFS04
Brass	.25"	0.1 to 1.0	0.5 to 5.0	24 VDC	TDFS05
				115 VAC	TDFS06
	.50"	1.5 to 12.0	4.0 to 20.0	24 VDC	TDFS07
				115 VAC	TDFS08
	.75"	-	5.0 to 30.0	24 VDC	TDFS09
				115 VAC	TDFS10
	1.00"	-	8.0 to 60.0	24 VDC	TDFS11
				115 VAC	TDFS12
Stainless Steel	9/16-18	0.1 to 1.0	0.5 to 5.0	24 VDC	TDFS13
				115 VAC	TDFS14
	.50"	1.5 to 12.0	4.0 to 20.0	24 VDC	TDFS15
				115 VAC	TDFS16
	.75"	-	5.0 to 30.0	24 VDC	TDFS17
				115 VAC	TDFS18
	1.00"	-	8.0 to 60.0	24 VDC	TDFS19
				115 VAC	TDFS20

Pressure Drop-Typical

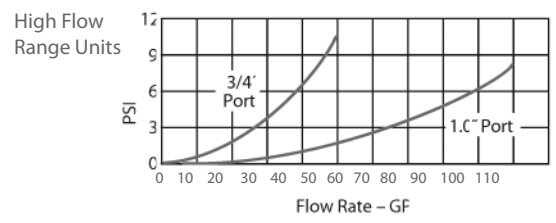
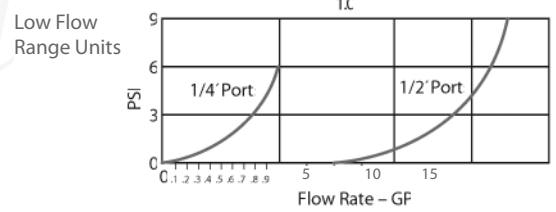
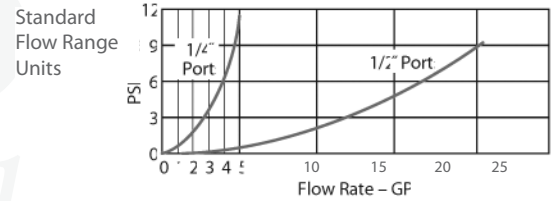

* With use of low flow adapter supplied
 ** Straight thread with O-Ring seal

