



ACURO™



ACURO with SSI Interface

DESCRIPTION

The Dynapar brand ACURO Absolute Encoder offers a modern full-feature design equipped with SSI interface.

The **Acuro AI25** optical absolute industrial encoder is available in a single-turn or multi-turn version. The multi-turn design is based on a reliable high-speed gear with optical scanning and the latest generation of OptoASIC technology.

The mechanical concept is based on a double ball bearing design, which is available as a solid-shaft or hollow-shaft version in common shaft diameters.

Series AI25™

Absolute Encoder With SSI Interface

APPLICATIONS:

Ideal for applications requiring digital feedback to be sent over an industrial bus network

- Elevators
- Machine Tool
- Assembly
- Positioning

INDUSTRIES

Manufacturing, Assembly, Material Handling and any other where precise, repeatable bidirectional position measurement is required.

FEATURES/BENEFITS

- Compact design to save valuable space
- Up to 17 Bit single-turn resolution
- 4096 revolutions of multi-turn resolution
- Short installation depth
- Safety through self-diagnostics
- Solid shaft and hollow shaft versions
- -40°C to +100°C Operating temperature
- Low power consumption
- Fast delivery of any model variant
- Additional field-bus and point-to-point interfaces available



ACURO with SSI Interface

Series AI25

Absolute Encoder With SSI Interface

SPECIFICATIONS*

STANDARD OPERATING CHARACTERISTICS

Single-turn Resolution: 10, 12, 13, 14, 17 Bit
Multi-turn Resolution: 12 bit (only available with 12 or 13 bit ST resolution)
Linearity: +/- 1/2 LSB
Absolute Accuracy: ±0.01° mechanical (36 arc-sec.)
Repeatability: ±0.002° mechanical (7.2 arc-sec.)
Code format: Binary, Gray, Gray Excess, parameterization through *AcuroSoft*
Parameterization: Resolution code type, sense of rotation, warning, alarm

ENVIRONMENTAL

Operating Temperature: -40 to 100° C
Storage Temperature: -40 to 100° C
Enclosure Rating: IP64 or IP67
Shock: 1,000 m/s² (6 ms)
Vibration: 100 m/s² (10 to 2,000 Hz)

ELECTRICAL

Connection: Cable, M23 - 12 pole Conin connector, M12- 8-pole connector
Supply voltage: 5 VDC -5%/+10% or 10-30 VDC
Intrinsic current consumption: 50 mA (ST), 100 mA (MT) not including output current
Output current: 60 mA per bit, short circuit protected
Frequency response: 500 kHz
Maximum cable length: 400 m
Control Inputs: Direction
Alarm output: Alarm bit
Status LED: Green = OK, Red = Alarm (IP64 only)
Preset Switch: Sets encoder to zero output at present mechanical position (IP64 only)

MECHANICAL

All Types
Maximum shaft speed: 10,000 RPM (continuous), 12,000 RPM (peak)
Starting torque: < 1.4 in-oz
Bearing life:
 1 x 10¹⁰ revolutions at 35% full rated shaft load
 1 x 10⁹ revolutions at 75% full rated shaft load
 1 x 10⁸ revolutions at 100% full rated shaft load
Weight (approx.): 350 g ST, 400 g MT

Shafted Types
Flange configurations: Square, Clamp, Servo
Shaft diameter: 6 mm (Servo Mount), 10 mm (Clamping Mount), 3/8" (Square Flange Mount)
Maximum shaft load:
 6 mm shaft: 13 lb axial, 24 lb radial
 10 mm shaft: 24 lb axial, 35 lb radial
 3/8" Shaft: 24 lb axial, 35 lb radial

Hubshaft Types
Flange configuration: Hubshaft with flexible tether
Accepted Mating Shaft Diameter (min./max.):
 6mm (5.984/5.996); 10mm (9.980/9.995);
 12 mm (11.976/11.994); 3/8" (.3742/.3748);
 1/2" (.4991/.4997)
Allowable Mating Shaft Movement (hubshaft only): +/- 1.5 mm axial, +/- 0.2 mm radial

* Specifications are for base models with standard features only unless otherwise noted. Specifications subject to change without notice in accordance with our DBS policy of continuous improvement. All product and brand names are trademarks of their respective owners. All rights reserved.

Dynapar™ brand ACURO™ and AI25™ are trademarks of Danaher Industrial Controls Group. All rights reserved. © 2005 DICG Corp.

Dynapar Brand AI25 SSI Data Sheet (8/05)

Code 1: Model	Code 2: Bits	Code 3: Mounting	Code 4: Shaft Size	Code 5: Protocol	Code 6: Electrical	Code 7: Connector
AI25	<input type="checkbox"/> <input type="checkbox"/> <input type="checkbox"/> <input type="checkbox"/>	<input type="checkbox"/>	<input type="checkbox"/>	<input type="checkbox"/>	<input type="checkbox"/>	<input type="checkbox"/>
AI25 Size25 Acuro Absolute Encoder	Single-Turn	Available when Code 4 is 0 or A	w/o shaft seal (IP64) 0 6 mm 1 3/8" 2 10 mm 3 3/8" Hub Shaft 4 12 mm Hubshaft 5 1/2" Hubshaft 6 10 mm Hub Shaft	2 SSI Gray 3 SSI Binary	0 5 VDC 2 10-30 VDC	0 1.5m axial cable 1 1.5m radial cable 2 M23 Conin 12 pin axial CW 3 M23 Conin 12 pin radial CW C M12, 8-pole connector axial D M12, 8-pole connector radial
	0010 10 Bit	0 Servo*				
	0012 12 Bit	Available when Code 4 is 2 or C				
	0013 13 Bit	1 Clamping*	w/ shaft seal (IP67) A 6 mm B 3/8" C 10 mm			
	0014 14 Bit	Available when Code 4 is 1 or B				
	0017 17 Bit	2 Square flange**				
	Multi-Turn	Available when Code 4 is 3, 4, 5 or 6				
	1212 12 Bit Multi-Turn, 12 Bit Single-Turn	3 Hubshaft w/tether†				
	1213 12 Bit Multi-Turn, 13 Bit Single-Turn	* 58mm Dia. ** 2.5" Square † 63mm BC				

Absolute Encoder With SSI Interface

Code 3: Mounting

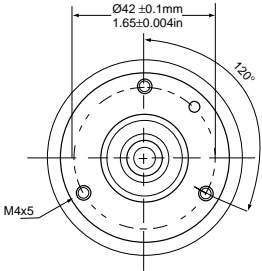

0 Servo

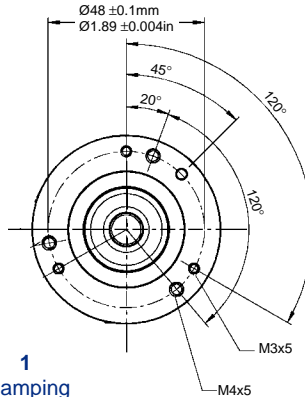
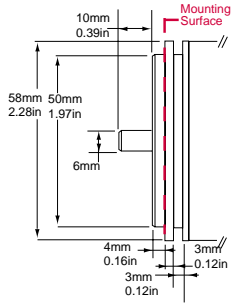

1 Clamping

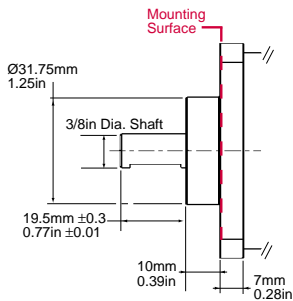
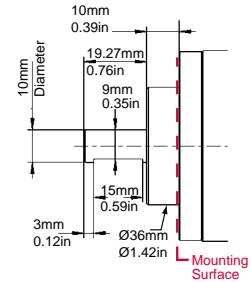

2 Square Flange

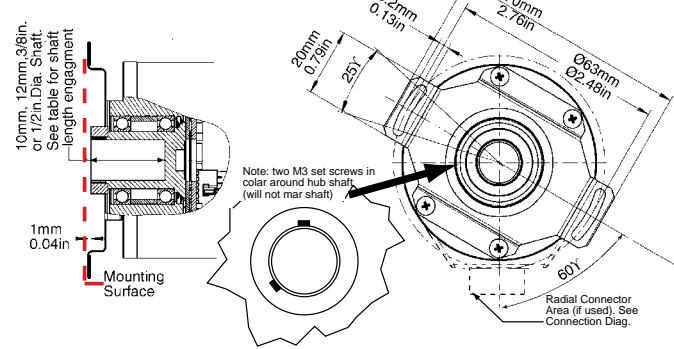
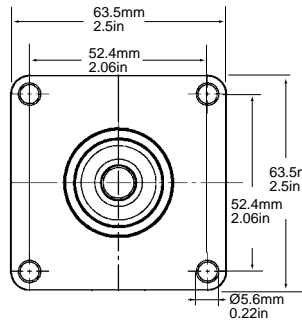

3 Hubshaft w/Tether

Hubshaft Shaft Engagement

HubShaft Diameter	Min. Shaft Length	Max. Shaft Length
10mm, 3/8"	15mm (0.59")	20mm (0.79")
12mm, 1/2"	18mm (0.71")	20mm (0.79")

Code 7: Connector

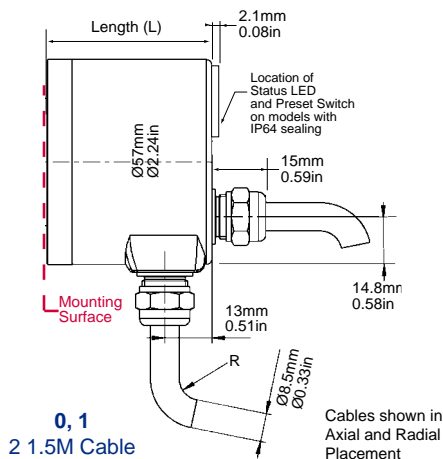

Length (L) Mounting Surface to Rear

Mount (Code 3)	Single-Turn	Multi-Turn
(0) Servo	46.5/1.83	46.5/1.83
(1) Clamping	45.5/1.79	45.5/1.79
(2) Square Flange	45.5/1.79	45.5/1.79
(3) Hubshaft	53.4/2.1	53.4/2.1

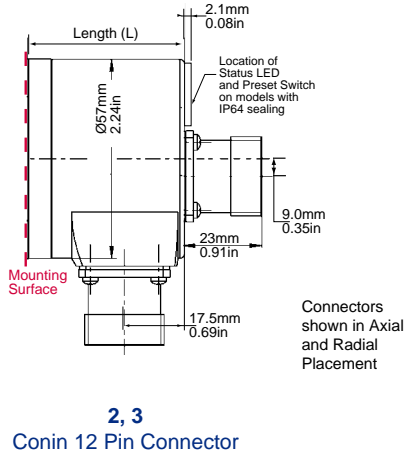

Length (L) Mounting Surface to Rear

Mount (Code 3)	Single-Turn	Multi-Turn
(0) Servo	46.5/1.83	46.5/1.83
(1) Clamping	45.5/1.79	45.5/1.79
(2) Square Flange	45.5/1.79	45.5/1.79
(3) Hubshaft	53.4/2.1	53.4/2.1

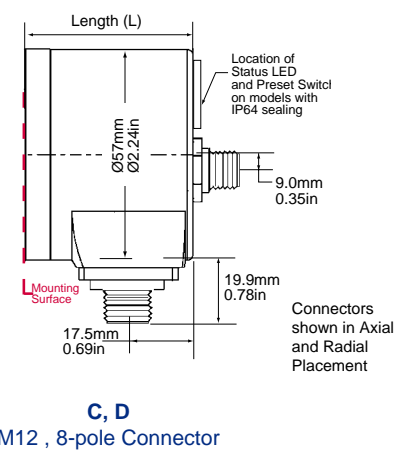

Length (L) Mounting Surface to Rear

Mount (Code 3)	Single-Turn	Multi-Turn
(0) Servo	46.5/1.83	46.5/1.83
(1) Clamping	45.5/1.79	45.5/1.79
(2) Square Flange	45.5/1.79	45.5/1.79
(3) Hubshaft	53.4/2.1	53.4/2.1

Absolute Encoder With SSI Interface

SSI Data Format

Bits	T1 - T10	T11	T12	T13	T14	T15	T16	T17	T18	T19
10	S9 - S0	0	0	0	0	S9	S8	S7	S6	S5
12	S11 - S2	S1	S0	0	0	S11	S10	S9	S8	S7
13	S12 - S3	S2	S1	S0	0	S12	S11	S10	S9	S8
14	S13 - S4	S3	S2	S1	S0	0	S13	S12	S11	S10
17	S16 - S7	S6	S5	S4	S3	S2	S1	S0	0	S16
Bits	T1 - T12	T13 - T21	T22	T23	T24	T25	T26	T27	T28	T29
1212	M11 - M0	S11 - S3	S2	S1	S0	0	0	M11	M10	M9
1213	M11 - M0	S12 - S4	S3	S2	S1	S0	0	M11	M10	M9

S9, S8 Data Bits for resolution per turn.

M11, M10 Data Bits for number of turns.

Electrical Connections 12 pin CONIN

Wire Color	Pin	Function
Brown	1	0V
Pink	2	Data
Yellow	3	Clock
—	4	N.C.
Blue	5	Direction
Red	6	N.C.
Violet	7	N.C.
White	8	5V/10-30V
—	9	N.C.
Gray	10	Data
Green	11	Clock
Black	12	0 V Data

12 pin CONIN Connector Part Number: G3 539 202

Bulk Cable (sold by the meter) Part Number: G3 280 220

Cable Assembly (with Connector)

- 3 meters Part Number: G1 542 003
- 5 meters Part Number: G1 542 004
- 10 meters Part Number: G1 542 005

S9 - S0 Data Bits S9, S8, S7, S6, S5, S4, S3 Etc.

M11 - M0 Turn Data Bits M11, M10, M9, M8, Etc.

Electrical Connections 8 pin M12

Wire Color	Pin	Function
White	1	5/10-30 Volt
Brown	2	0 Volt
—	3	N.C.
Green	4	Clock
Pink	5	Data
Yellow	6	Clock
Blue	7	Direction
Gray	8	Data

8 pin M12 Connector Part Number: G3 539 597

Bulk Cable (sold by the meter) Part Number: G3 280 251

Cable Assembly (with Connector)

- 3 meters Part Number: G1 565 329
- 5 meters Part Number: G1 565 330
- 10 meters Part Number: G1 565 331



Gordy's Sensors

5772 Smaller Rd, Johnstown, OH 43031 Phone: (740) 967-2283 Fax: (740) 967-2855
 Website: www.gordyssensors.com or Email: sales@gordyssensors.com