

**BTL5-P/I/K/L/M/N/R\_-M\_-\_-\_-B/Z-S 32/KA\_-\_-**

Micropulse Linear Transducer

Digital Output / Rod Style



**BTL5-P/I/K/L/M/N/R \_\_\_ -B/Z-S 32/KA \_\_\_**  
**Micropulse Linear Transducer -**  
**Digital Output - Rod Style**

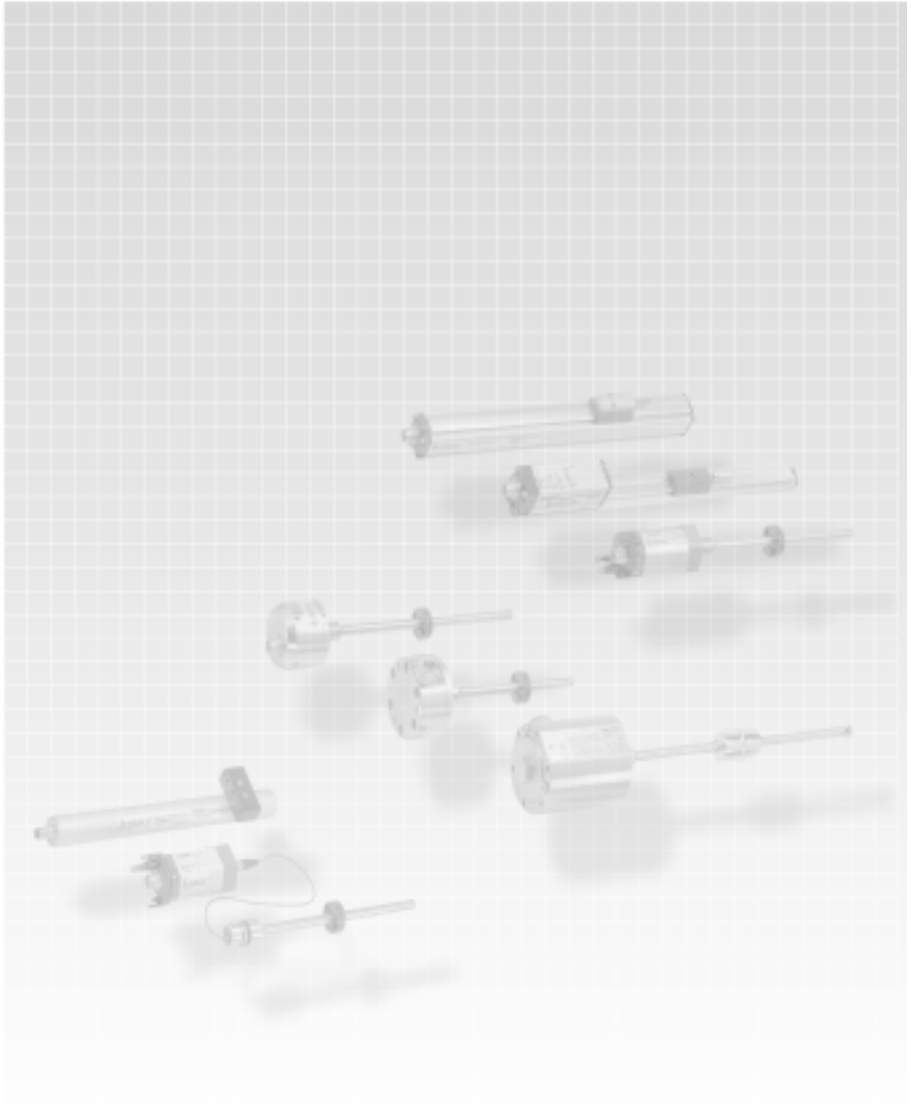



# BTL5-P/I/K/L/M/N/R \_\_\_ -B/Z-S 32/KA \_\_\_

## Micropulse Linear Transducer - Digital Output - Rod Style

1	2	3	4	5	6	7	8	9	10	11	12	13	14	15	16	17	18	19	20	21	22	23
B	T	L	-	5	-	P	1	-	M	0	3	0	5		Z	-	S	3	2	-	E	4
																	K	A	0	5		

**Balluff - Linear Transducer** \_\_\_\_\_

**Generation 5** \_\_\_\_\_

**Output Type** \_\_\_\_\_

- I = Differential start/stop with tri-state
- K = Differential stop - leading edge active
- L = Differential pulse-width modulated
- M = Differential start/stop - leading edge active
- N = Single ended start/stop - leading edge active
- P = Differential start/stop - trailing edge active
- R = Differential pulse width modulated with recirculations

**Supply Voltage** \_\_\_\_\_

- 1 = 24 Vdc ±20%
- 2 = ±15 Vdc ±2%

**Normal Stroke Length** \_\_\_\_\_

0	3	0	5
---	---	---	---

 = 305mm active stroke

**Housing Type** \_\_\_\_\_

- Z = Standard Rod Style (3/4"x16-UNF mounting threads and 50.8mm null zone)
- B = Metric Rod Style (M18x1.5 mounting threads and 30mm null zone)

**Connection Type** \_\_\_\_\_

S	3	2
---	---	---

 = 8-pin quick disconnect metal connector

K	A	0	5
---	---	---	---

 = Cable out (5m standard; specify length in meters)

**Interrogation (R output only, otherwise leave blank)** \_\_\_\_\_

- I = Internal Interrogation
- E = External Interrogation

**Recirculation ( output only, otherwise leave blank)** \_\_\_\_\_

- 1 = 1 circulation, 2 = 2 circulations, 4 = 4 circulations, 8 = 8 circulations, 16 = 16 circulations

**Standard Stroke Lengths** (consult factory for additional lengths)

**Electrical Stroke**

inches	mm	inches	mm	inches	mm	inches	mm
2	0051	13	0330	40	1016	142	3606
3	0077	15	0381	42	1067	148	3759
3.5	0090	16	0407	48	1220	156	3962
4	0102	18	0457	50	1270		
5	0127	20	0508	60	1524		
6	0152	22	0560	70	1778		
7	0178	24	0610	80	2032		
8	0203	26	0661	90	2286		
9	0230	28	0711	100	2540		
10	0254	30	0762	110	2794		
11	0280	32	0813	120	3048		
12	0305	36	0914	130	3302		



**Contents**

**1 Safety Advisory** ..... 2  
 1.1 Proper application ..... 2  
 1.2 Qualified personnel ..... 2  
 1.3 Use and inspection ..... 2  
 1.4 Scope ..... 2

**2 Function and Characteristics** ..... 3  
 2.1 Characteristics ..... 3  
 2.2 Function ..... 3  
 2.3 Available stroke lengths and magnet ..... 3

**3 Installation** ..... 3  
 3.1 Mounting ..... 3  
 3.2 Transducer, Installation ..... 4  
 3.3 Magnets, Installation ..... 5

**4 Wiring** ..... 5

**5 Startup** ..... 7  
 5.1 Check connections ..... 7  
 5.2 Turning on the system ..... 7  
 5.3 Check output values ..... 7  
 5.4 Check functionality ..... 7  
 5.5 Fault conditions ..... 7

**6 Versions (indicated on part label)** ..... 7

**7 Technical Data** ..... 8  
 7.1 Dimensions, weights, ambient conditions ..... 8  
 7.2 Supply voltage (external) ..... 8  
 7.3 Control signals ..... 8  
 7.4 Connection to processor ..... 8  
 7.5 Included in shipment ..... 8  
 7.6 Magnets (order separately) ..... 8  
 7.7 Accessories (optional) ..... 8  
 7.8 Compatible processors and displays ..... 8

**8 Recirculated Output Programming Instructions** ..... 10  
 8.1 Scope ..... 10  
 8.2 Tools Required ..... 10  
 8.3 Accessing the DIP Switches ..... 10  
 8.4 Programming ..... 10  
 8.5 Assembly ..... 10

**1 Safety Advisory**

Read this manual before installing and operating the Micropulse Transducer.

**1.1 Proper application**

The BTL5 Micropulse transducer is intended to be installed in a machine or system. Together with a controller (PLC) or a processor (BTA) it comprises a position measuring system and may only be used for this purpose.

Unauthorized modifications and non-permitted usage will result in the loss of warranty and liability claims.

**1.2 Qualified personnel**

This guide is intended for specialized personnel who will perform the installation and setup of the system.

**1.3 Use and inspection**

The relevant safety regulations must be followed when using the transducer system. In particular, steps must be taken to ensure that should the transducer system become defective no hazards to persons or property can result. This includes the installation of additional safety limit switches, emergency shutoff switches and maintaining the permissible ambient conditions.

**1.4 Scope**

This guide applies to the model BTL5-P/I/K/L/M...B/Z... Micropulse transducer.

An overview of the various models can be found in section 6 Versions (indicated on product label) on page 7.

**Note:** For special versions, which are indicated by an -SU\_\_ designation in the part number, other technical data may apply (affecting calibration, wiring, dimensions etc.).

The following patents have been granted in connection with this product:

**US Patent 5 923 164**  
 Apparatus and Method for Automatically Tuning the Gain of an Amplifier

**US Patent 5 903 426**  
 Overvoltage Protection Apparatus for Data Interface

**CE** The CE Mark verifies that our products meet the requirements of EC Directive

89/336/EEC (EMC Directive)

and the EMC Law. Testing in our EMC Laboratory, which is accredited by DATech for Testing Electromagnetic Compatibility, has confirmed that Balluff products meet the EMC requirements of the following Generic Standards:

EN 50081-2 (emission)  
 EN 61000-6-2 (noise immunity)

Emission tests:

RF Emission  
 EN 55011 Group 1, Class A

Noise immunity tests:

Static electricity (ESD)  
 EN 61000-4-2 Severity level 3

Electromagnetic fields (RFI)  
 EN 61000-4-3 Severity level 3

Fast transients (Burst)  
 EN 61000-4-6 Severity level 3

Surge  
 EN 61000-4-5 Severity level 2

Line-induced noise induced by high-frequency fields  
 EN 61000-4-6 Severity level 3

Magnetic fields  
 EN 61000-4-8 Severity level 4

**2 Function and Characteristics**

**2.1 Characteristics**

Micropulse transducers feature:

- Very high resolution, repeatability and linearity
- Bus-compatible interface (BTL5-I...)
- Immunity to shock, vibration, contamination and electrical noise
- An absolute output signal
- Wear- and maintenance-free
- BTL to processor cable lengths up to 500 m
- Pressure rated to 600 bar
- IP 67 per IEC 529

**2.2 Function**

The transducer contains a tubular waveguide enclosed by an outer stainless steel rod. A magnet attached to the moving member of the machine or to the cylinder piston is moved over the rod and its position constantly updated.

The magnet defines the measured position on the waveguide. An externally generated INIT pulse interacts with the magnetic field of the magnet to generate a magnetostrictive torsional wave in the waveguide which propagates at ultrasonic speed.

The torsional wave arriving at the end of the waveguide is absorbed in the damping zone. The wave arriving at the beginning of the waveguide creates an electrical signal in the coil surrounding the waveguide. The propagation time of the wave is used to determine the position, which is presented on the output in various digital formats. This takes place with high precision and repeatability within the measuring range indicated as the nominal stroke length.

At the rod end is a damping zone, within which no reliable signal is available, but which may be entered by the magnet.

The electrical connection between the transducer, the processor/controller and the power supply is via a cable, which depending on the version is either fixed or connected using a female connector.

Dimensions for installing the Micropulse transducer: Fig. 3-2 Dimensions for installing the magnet: Fig 3-4

**2.3 Available stroke lengths and magnets**

To provide for optimum fit in any application, a wide range of standard stroke lengths and magnets in various form factors are available. Magnets must therefore be ordered separately.

See inside front cover for available stroke lengths.

**3 Installation**

**3.1 Mounting**

When possible, use non-magnetizable material for attaching the transducer and magnet ring. Fig. 3-1.

*When attaching the transducer to magnetizable materials, appropriate measures must be taken to protect against magnetic disturbances Fig. 3-1. Note the recommended distance of the transducer and cylinder from strong, external magnetic fields.*

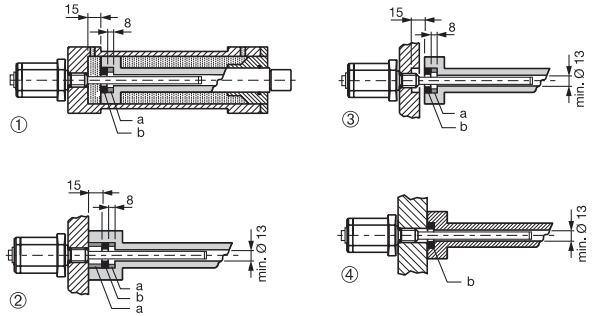

- ① - ③ for magnetizable materials
- ④ for non-magnetizable materials

- a = Spacer made of non-magnetizable materials
- b = Magnet

Fig. 3-1: Mounting

**BTL5-P/I/K/L/M/N/R -M -B/Z-S 32/KA**  
**Micropulse Linear Transducer -**  
**Digital Output - Rod Style**



**3 Installation (cont.)**

Electrical connection  
**BTL5...B/Z-KA05**

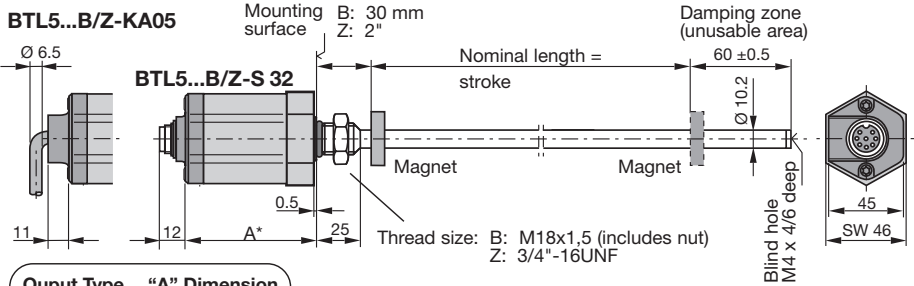

Opout Type	"A" Dimension
K, I, L, M, N, P	A = 57
R	A = 74

Fig. 3-2: Transducer BTL5...B/Z, Dimensions

**Important Installation Notes:**

The contact surface of the transducer must be completely contacted by the mounting surface. The O-ring supplied must make a perfect pressure seal, i.e. the bevel for the O-ring must be configured exactly as shown in Fig. 3-3.

To achieve secure mounting, use the proper nut for the mounting thread. When tightening the nut, do not exceed a tightening torque of 100 Nm.

For horizontal mounting of transducer with stroke lengths greater than 500 mm, the pressure tube should be supported or attached at its end.

When installing in a hydraulic cylinder, do not allow the magnet ring to rub against the pressure tube. The bore diameter in the piston and cylinder rod should be at least 13 mm.

When attaching the transducer to magnetizable materials, appropriate measures must be taken to protect against magnetic disturbances, Fig. 3-1.

Note the recommended distance of the transducer and cylinder from strong, external magnetic fields.

**3.2 Transducer, Installation**

The smallest permissible distance between magnet ring and rod mounting surface is shown in Fig. 3-2.

The transducer has either a M18x1,5 thread or a 3/4"-16UNF thread for mounting. The sealing is carried out with the O-ring supplied at the flange facing.

Threaded hole  
 M18 x 1,5 per  
 ISO 6149  
 O-ring 15.4 x 2.1

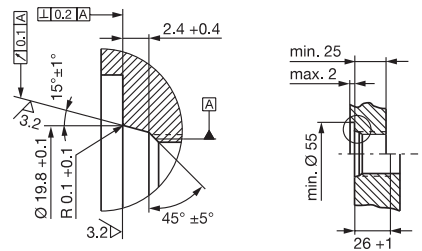

Threaded hole  
 3/4"-16UNF per  
 SAE J475  
 O-ring 15.3 x 2.4

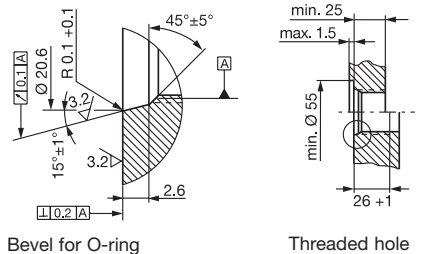

Fig. 3-3: Threaded hole for mounting the BTL with O-ring

**3 Installation (cont.)**

**3.3 Magnets, Installation**

A magnet is required for each transducer. This must be ordered separately. Fig. 3-4.

For mounting the magnet we recommend to use non-magnetizable material. Fig. 3-1.

**BTL-P-1013-4R**

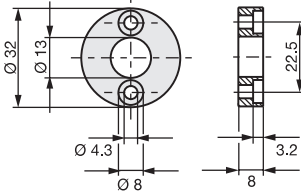

**BTL-P-1013-4S**

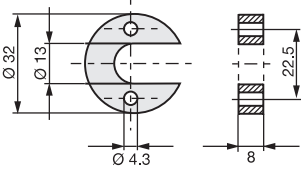

**BTL-P-1012-4R**

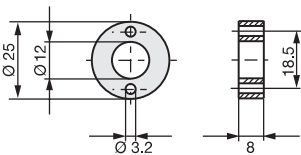

Fig. 3-4: Magnet (optional)

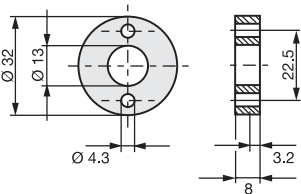

Fig 3-5: Spacer

**4 Wiring**

Note the following when making electrical connections:



System and control cabinet must be at the same ground potential.

To ensure the electromagnetic compatibility (EMC) which Balluff warrants with the CE Mark, the following instructions must be strictly followed.

BTL transducer and the processor/control must be connected using shielded cable.

Shielding: Copper filament braided, 80% coverage.

The shield must be tied to the connector housing in the BKS connector (Fig. 4-1); see instructions accompanying the connector.

In the cable version the cable shield is connected to the housing in the PG fitting.

The cable shield must be grounded on the control side, i.e., connected to the protection ground.

Pin assignments can be found in Table 4-1. Connections on the controller side may vary according to the controller and configuration used.

When routing the cable between the transducer, controller and power supply, avoid proximity to high voltage lines to prevent noise coupling. Especially critical is the inductive noise caused by AC harmonics (e.g. from phase-control devices), against which the cable shield provides only limited protection.

Cable length max. 500 m;  
 Ø 6 to 8 mm.

High noise immunity on the line between the transducer and processor is provided by the differential line drivers used for the RS 485/422 interface. The differential signal is carried to the processor, which makes it available as analog or digital information for further processing.

straight **BKS-S 32M-00** right-angle **BKS-S 33M-00**

Cable entry (PG 9 fitting)

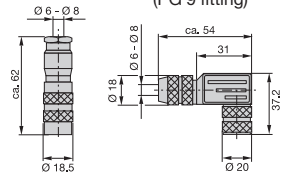

Fig. 4-1: Connector (optional)

**BTL5-P/I/K/L/M/N/R\_-M\_\_\_\_-B/Z-S 32/KA\_**  
**Micropulse Linear Transducer -**  
**Digital Output - Rod Style**



**4 Wiring (cont.)**

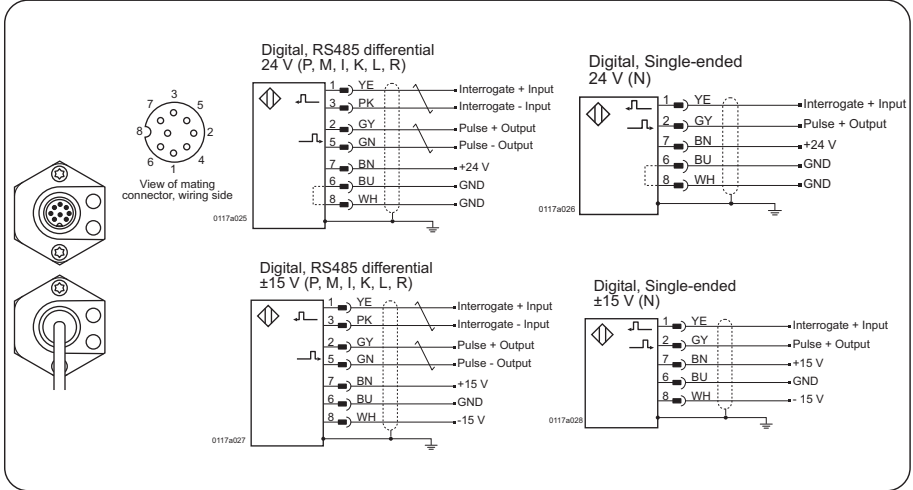

Table 4-1: Wiring

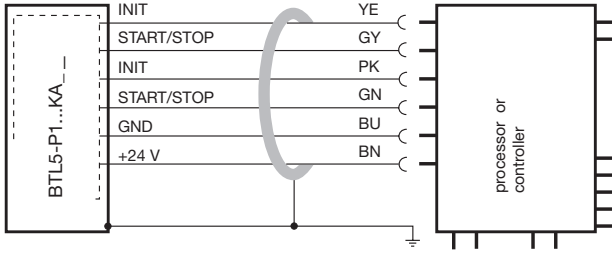

Fig. 4-2: BTL5-P1...KA\_ with processor controller, wiring example

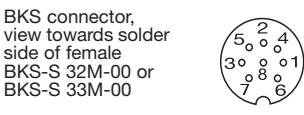

Fig. 4-3: Pin assignments BKS, connector type BTL

### 5 Startup

#### 5.1 Check connections

Although the connections are polarity reversal protected, components can be damaged by improper connections and overvoltage. Before you apply power, check the connections carefully.

#### 5.2 Turning on the system

Note that the system may execute uncontrolled movements when first turned on or when the transducer is part of a closed-loop system whose parameters have not yet been set.

Therefore make sure that no hazards could result from these situations.

#### 5.3 Check output values

After replacing or repairing a transducer, it is advisable to verify the values for the start and end position of the magnet in manual mode. If values other\* than those present before the replacement or repair are found, a correction should be made.

\* Transducers are subject to modification or manufacturing tolerances.

#### 5.4 Check functionality

The functionality of the transducer system and all its associated components should be regularly checked and recorded.

#### 5.5 Fault conditions

When there is evidence that the transducer system is not operating properly, it should be taken out of service and guarded against unauthorized use.

### 6 Versions (indicated on part label)

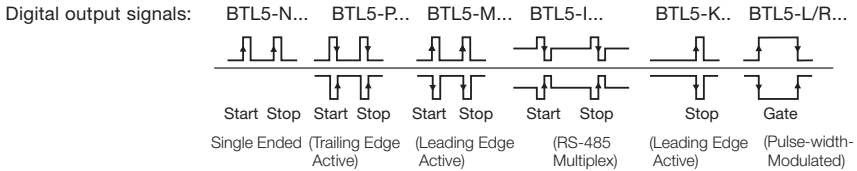
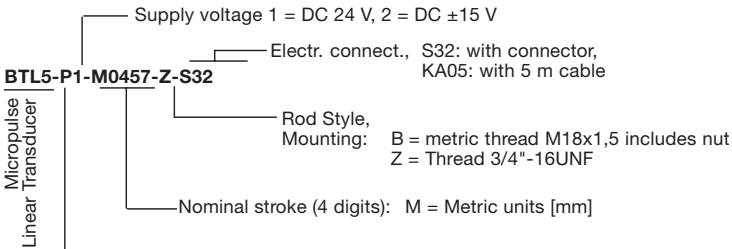

# BTL5-P/I/K/L/M/N/R\_-M\_\_\_\_-B/Z-S 32/KA\_\_

## Micropulse Linear Transducer - Digital Output - Rod Style



### 7 Technical Data

Typical values at DC 24 V and 25 °C. Ready for operation at once, full accuracy after warm-up. With magnet: BTL-P-1013-4R, BTL-P-1013-4S or BTL-P-1012-4R:

Resolution	≤ 2 µm
Hysteresis	≤ 4 µm
Repeatability	≤ 6 µm
(resolution + hysteresis)	
System resolution (BTL5-... + BTA)	
is determined by the processor or external controller.	

Recommended sampling rate:

Nominal length	f <sub>Standard</sub>
≤ 1000 mm	0.5 to 2 kHz
≤ 2000 mm	0.5 to 1 kHz
> 2000 mm	0.5 kHz

Non-linearity:

Nom. length ≤ 500 mm	> 500 mm
±100 µm	±0.02 % FS

Temperature coefficient

≤ (6 µm + 5 ppm · nominal length)/K

- Shock loading 100 g/6 ms  
per IEC 68-2-27<sup>1</sup>  
100 g/2 ms  
per IEC 68-2-29<sup>1</sup>
- Continuous shock 12g, 10 bis 2000 Hz  
per IEC 68-2-6<sup>1</sup>
- (take care to avoid inherent resonances of protective tube)
- Pressure up to 600 bar  
when installed in a hydraulic cylinder

<sup>1</sup> Individual specifications as per Balluff factory standard

#### 7.1 Dimensions, weights, ambient conditions

- Nominal length ≤ 4000 mm
- Dimensions Fig. 3-2
- Weight ca. 2 kg/m
- Housing anodized aluminum
- Pressure tube stainless steel  
1.4571
- Diameter 10.2 mm
- Wall thickness 2 mm
- E-modulus ca. 200 kN/mm<sup>2</sup>
- Mounting sM18 x 1.5 or threads  
3/4" -16UNF
- Operating temp. -40 °C to +85 °C
- Humidity < 90 %, non-condensing
- Protection rating IP67  
per IEC 529 with connector attached

#### 7.2 Supply voltage (external)

Regulated supply voltage	BTL5-... DC 20 to 28 V
Ripple	≤ 0.5 V <sub>PP</sub>
BTL5-... DC	±14.7 to ±15.3 V
Current draw	≤ 90 mA (at 1 kHz)
Inrush	≤ 3 A/0.5 ms
Polarity reversal protection	built-in
Overvoltage protection	
Transzorb diodes	
Electric strength	
GND to housing	500 V

#### 7.3 Control signals

INIT pulse	
Level	+5 V RS 485/422 driver
Length	1 µs (max. 3 µs)

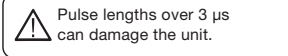

#### 7.4 Connection to processor

Shielded cable,  
max. length 500 m, Ø 6 to 8 mm

#### 7.5 Included in shipment

Transducer Fig. 3-2

#### 7.6 Magnets (order separately)

**Magnets BTL-P-1013-4R,  
BTL-P-1013-4S, BTL-P-1012-4R**

Dimensions	Fig. 3-4
Weight	approx. 10 g
Housing	anodized aluminum
Operating temp.	-40 °C to +85 °C

**Magnets BTL5-P-4500-1**

(Electromagnet)	
Weight	approx. 90 g
Housing	plastic
Operating temp.	-40 °C to +60 °C

#### 7.7 Accessories (optional)

Connectors Fig. 4-1

#### 7.8 Compatible processors and displays

... for BTL5-P1

Analog output processor cards:

BTA-A	0...10 and 10...0 V
BTA-C	0...20 or 20...0 mA *
BTA-E	4...20 or 20...4 mA *
BTA-G	-10...10 and 10...-10 V
* also:	0...10 V and 10...0 V

Digital output processor cards:

BTA-D11	20 bit, binary
BTA-S11	16 setpoint outputs
BTA-H11	22 bit, BCD
SSD =	Gray/binary or Gray
BTA-V11	Velocity output card
Parallel, digital and analog output	

Displays:

BDD-07-9 digital display, 7-digit for BTA-H, BTA-S and BTA-V  
BDD-AM10-1-P display and controller with 2 relay outputs  
BDD-CC08-1-P display and controller with 8 setpoints

... for BTL5-I1

Processor/controller:

BTA-M11 high-resolution digital processor  
Process Module Transsonar PMT

**7 Magnet and Connector Reference Diagram**

Electrical connection

**BTL5...B/Z-KA05**

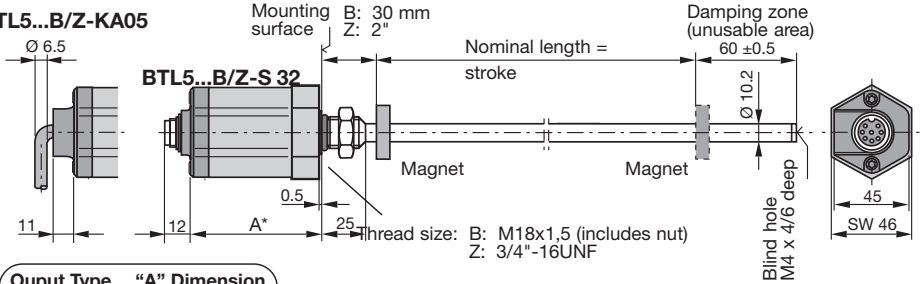

Output Type	"A" Dimension
K, I, L, M, N, P	A = 57
R	A = 74

Fig. 3-2: Transducer BTL5...B/Z, Dimensions

**BTL-P-1013-4R**

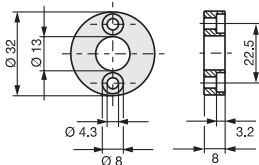

**BTL-P-1013-4S**

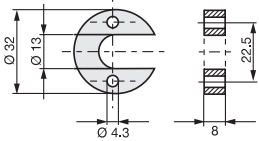

**BTL-P-1012-4R**

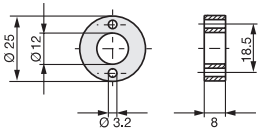

Fig. 3-4: Magnet (optional)

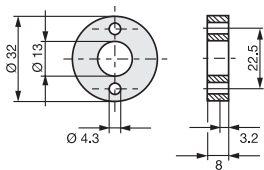
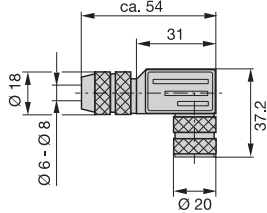

Fig 3-5: Spacer

right-angle  
**BKS-S 33M-00**



straight  
**BKS-S 32M-00**

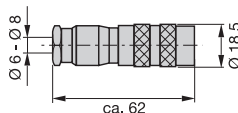

Fig. 4-1: Connector (optional)

**8 Recirculated Output Programming Instructions**

**8.1 Scope**

This document contains information relevant to Balluff Linear Transducers with recirculated pulse-width-modulated (PWM) output only (output code R only).

The information in this document can be used to:

- 1) Change the effective system resolution by increasing or decreasing the number of recirculations.
- 2) Change the Interrogation mode (Internal or External).
- 3) Change the Update Rate (Internal Interrogation mode only).

**8.2 Tools Required**

The following tools are required to perform this procedure:

- 3 mm Hex Wrench
- Small flathead screwdriver (jewelers screwdriver)
- Thread-locking compound (Loc-Tite 242 or equivalent)

**Procedure**

**8.3 Accessing the DIP switches**

1. Use the 3 mm hex wrench to remove the 2 screws which attach the electronics head to the pressure tube assembly.

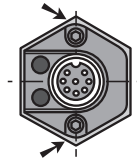

**Note:**  
Take care not to twist the flex-band which connects the electronics head to the transducer flange.

2. Carefully pull the electronics head **no more than 2"** away from the flange of the pressure tube.

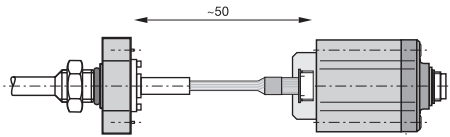

3. Locate the DIP switches on circuit board #2.

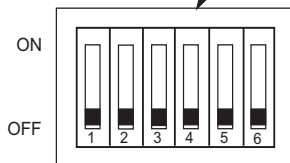
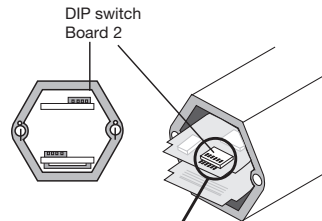

*This procedure should be performed by authorized and trained personnel only.*

*Failure to follow these instruction may result in damage to equipment and/or loss of warranty.*

*Disconnect power to transducer before performing any of the procedures described in this document.*

**8 Recirculated Output Programming Instructions (cont.)**

**8.4 Programming**

1. Use the tables below to determine the correct switch settings.

1	2	3	Interrogation Mode
Off	Off	Off	External Interrogation
Off	Off	On	Internal Interrogation 2 ms update
Off	On	Off	Internal Interrogation 4 ms update
Off	On	On	Internal Interrogation 8 ms update
On	Off	Off	Internal Interrogation 12 ms update
On	Off	On	Internal Interrogation 16 ms update
On	On	Off	Internal Interrogation 20 ms update
On	On	On	Internal Interrogation 24 ms update

To determine optimum output rate, use the following formula:

$$\text{stroke length (in.)} + 3 \times 0.009 \times \text{desired number of recirculations} = \text{minimum update rate in milliseconds (ms)}$$

4	5	6	Number of Recirculations
Off	Off	Off	1
Off	Off	On	2
Off	On	Off	3
Off	On	On	4
On	Off	Off	6
On	Off	On	8
On	On	Off	10
On	On	On	16

To determine the number of recirculations, use the following formula:

$$\text{Number of recirculations} \leq \frac{\text{Update Rate (ms)}}{\text{Stroke Length (in.)} + 3 \times 0.009}$$

2. Use the tip of the small, flathead screwdriver to slide the DIP switches to the desired position.

**8.5 Assembly**

- Carefully slide the electronics head back onto the pressure tube assembly, being careful not to pinch the flex-band.
- Apply a small amount of thread-locking compound to the 2 hex screws and tighten using the 3 mm hex wrench.



Do not overtighten. Screws should be tightened using no more than 2 ft-lbs. of torque.

**BTL5-P/I/K/L/M/N/R\_-M\_\_\_\_-B/Z-S 32/KA\_\_**  
**Micropulse Linear Transducer -**  
**Digital Output - Rod Style**

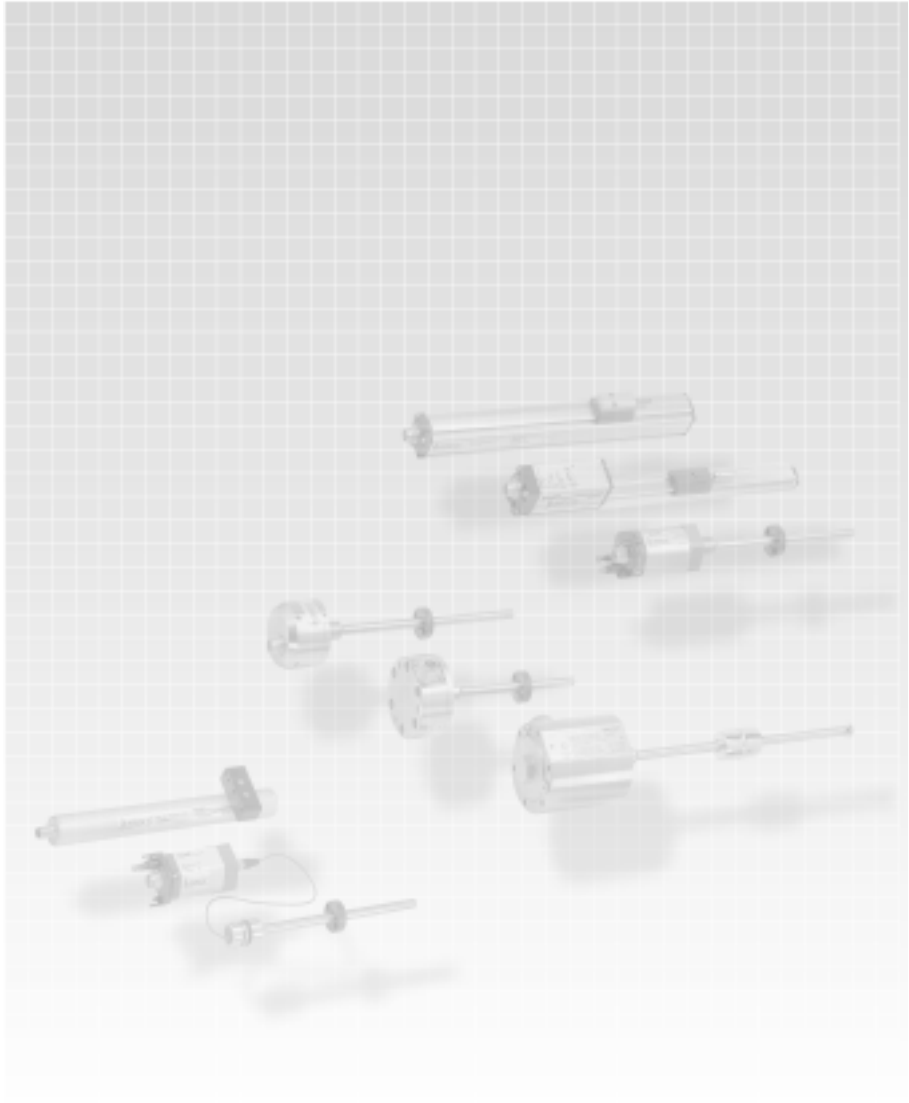



**BTL5-P/I/K/L/M/N/R\_-M\_\_\_\_\_-B/Z-S 32/KA\_**  
**Micropulse Linear Transducer -**  
**Digital Output - Rod Style**

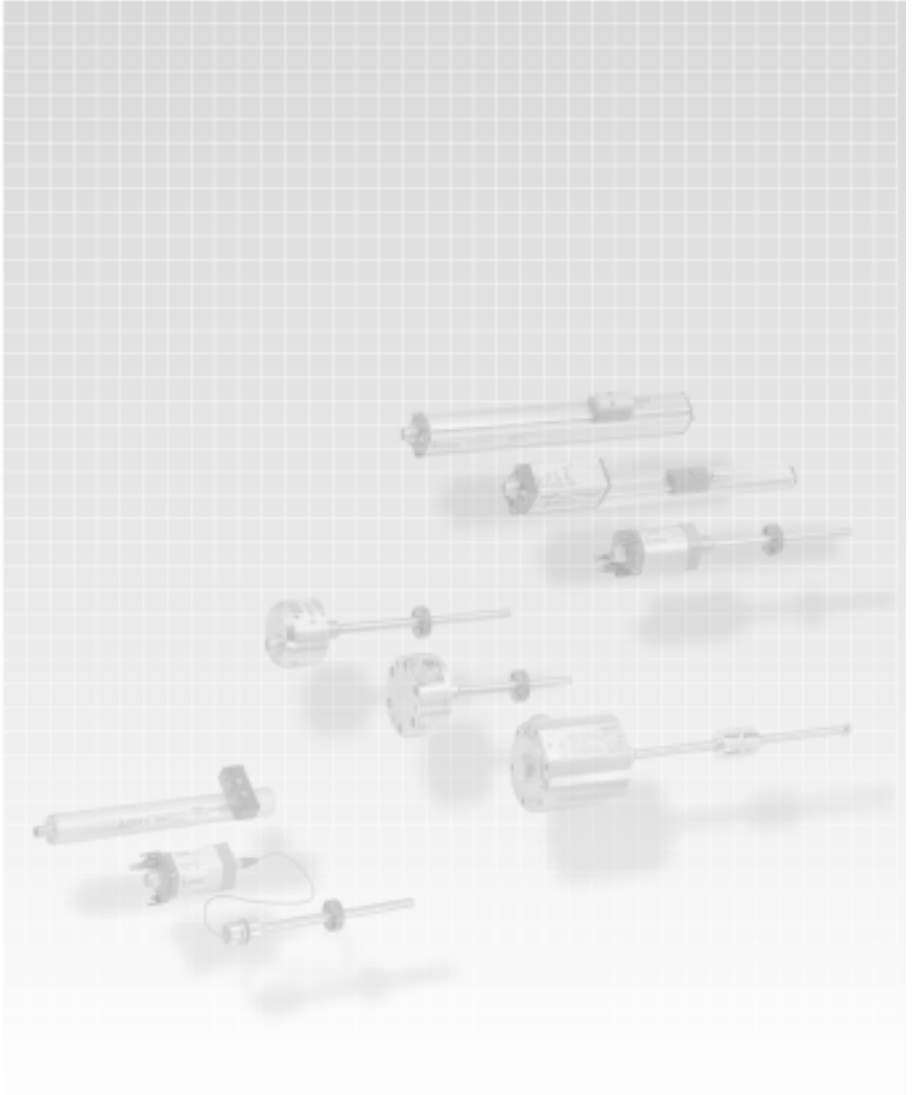

## Complete Product Range



*Inductive  
Sensors*



*Optoelectronic  
Sensors*



*Micropulse™  
Transducers*

### Germany

#### Global Headquarters

Balluff GmbH  
Schurwaldstraße 9  
73765 Neuhausen a.d.F.  
Telefon: +49 (0)71 58/1 73-0  
Telefax: +49 (0)71 58/50 10  
Hotline: +49 (0)71 58/1 73-370  
Web: [www.balluff.de](http://www.balluff.de)  
E-mail: [balluff@balluff.de](mailto:balluff@balluff.de)

### USA

#### North American Headquarters

Balluff Inc.  
8125 Holton Drive  
Florence, KY 41042  
Phone: (859) 727-2200  
Toll-free: 1-800-543-8390  
Fax: (859) 727-4823  
Web: [www.balluff.com](http://www.balluff.com)  
E-Mail: [balluff@balluff.com](mailto:balluff@balluff.com)

### Canada

Balluff Canada, Inc.  
2840 Argentia Road, Unit #2  
Mississauga, Ontario L5N 8G4  
Phone: (905) 816-1494  
Toll-free: 1-800-927-9654  
Fax: (905) 816-1411  
Web: [www.balluff.ca](http://www.balluff.ca)  
E-mail: [balluff.canada@balluff.ca](mailto:balluff.canada@balluff.ca)

### Mexico

Balluff de Mexico S.A. de C.V.  
Fray Pedro de Gante 25 P.B.  
Col. Cimatarío  
Queretaro, QRO 76030  
Phone: (+52 442) 212-4882,  
224-3583, 224-3171  
Fax: (+52 442) 214-0536  
Web: [www.balluff.com.mx](http://www.balluff.com.mx)  
E-mail: [balluff.mexico@balluff.com](mailto:balluff.mexico@balluff.com)



*Capacitive  
Sensors*



*Magnetic Field  
Sensors*



*Electromechanical  
Sensors*



*Identification  
Systems*



*Connectors &  
Accessories*