

BTL5-A/C/E/G__-M___-B/Z-S32/KA__

Micropulse Linear Transducer
Analog Output-Rod Style

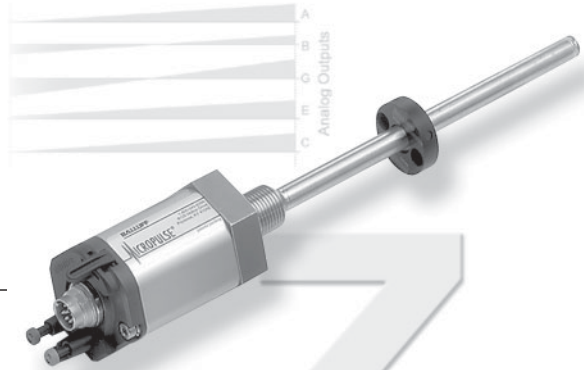

BTL5-A/C/E/G__M__-B/Z-S32/KA__
Micropulse Linear Position Transducer
Analog Output-Rod Style

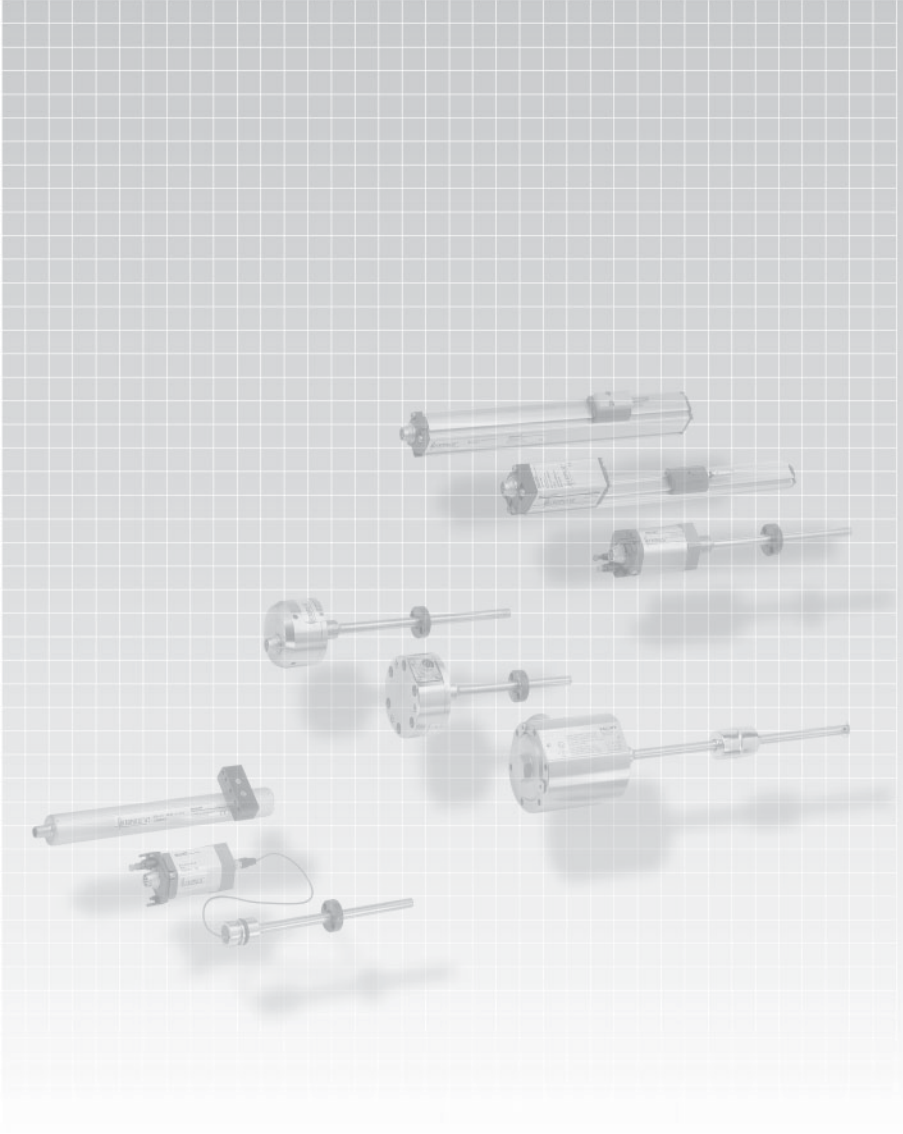



BTL5-A/C/E/G__-M__-B/Z-S32/KA__
Micropulse Linear Position Transducer
Analog Output-Rod Style

1	2	3	4	5	6	7	8	9	10	11	12	13	14	15	16	17	18	19	20	21	22
B	T	L	-	5	-	A	1	1	-	M	0	3	0	5	-	Z	-	S	3	2	-
																		K	A	0	5

Balluff - Linear Transducer

Generation 5

Output Type

- A = 0 to 10Vdc
- B = -5 to +5Vdc
- C = 0 to 20 mA
- E = 4 to 20 mA
- G = -10 to +10 Vdc

Supply Voltage

- 1 = 24 Vdc ±20%
- 2 = ±15 Vdc ±2%

Analog Output Operation

- Voltage type (Output type A, B & G)
- 1 = User selectable rising or falling
- Current type (Output type C & E)
- 0 = Minimum output at connector end (rising towards opposite end)
- 7 = Maximum output at connector end (falling towards opposite end)

Normal Stroke Length

= 305mm active stroke

Housing Type

- Z = Standard Rod Style (3/4"x16-UNF mounting threads and 50.8mm null zone)
- B = Metric Rod Style (M18x1.5 mounting threads and 30mm null zone)

Connection Type

= 8-pin quick disconnect metal connector

= Cable out (5m standard; specify length in meters)

Standard Stroke Lengths (consult factory for additional lengths)

Electrical Stroke

inches	mm	inches	mm	inches	mm	inches	mm
2	0051	13	0330	40	1016	142	3606
3	0077	15	0381	42	1067	148	3759
3.5	0090	16	0407	48	1220	156	3962
4	0102	18	0457	50	1270		
5	0127	20	0508	60	1524		
6	0152	22	0560	70	1778		
7	0178	24	0610	80	2032		
8	0203	26	0661	90	2286		
9	0230	28	0711	100	2540		
10	0254	30	0762	110	2794		
11	0280	32	0813	120	3048		
12	0305	36	0914	130	3302		

Contents

1 Safety Advisory 2

1.1 Proper application 2

1.2 Qualified personnel 2

1.3 Use and inspection 2

1.4 Scope 2

2 Function and Characteristics 3

2.1 Characteristics 3

2.2 Function 3

2.3 Available stroke lengths and magnets 3

3 Installation 3

3.1 Mounting 3

3.2 Transducer, Installation 4

3.3 Magnets, Installation 5

4 Wiring 5

5 Startup 6

5.1 Check connections 6

5.2 Turning on the system 6

5.3 Check output values 6

5.4 Check functionality 6

5.5 Fault conditions 6

6 Calibration procedure 6

6.1 Selecting calibration mode 7

6.2 Teach-in 7

6.3 Manual adjust 7

6.4 Reset 7

6.5 Online-setting 7

7 Teach-in mode 8

8 Manual adjust mode 9

9 Resetting all values (Reset) 10

10 Online-setting mode 11

11 Technical Data 12

11.1 Dimensions, weights, ambient conditions 12

11.2 Supply voltage (external) 12

11.3 Outputs 12

11.4 Connection to controller 12

11.5 Included in shipment 12

11.6 Magnets 12

11.7 Accessories (optional) 12

12 Versions (indicated on product label) 12

1 Safety Advisory

Read this manual before installing and operating the Micropulse Transducer.

1.1 Proper application

The BTL5 Micropulse transducer is intended to be installed in a machine or system. Together with a controller (PLC) it comprises a position measuring system and may only be used for this purpose.

Unauthorized modifications and non-permitted usage will result in the loss of warranty and liability claims.

1.2 Qualified personnel

This guide is intended for specialized personnel who will perform the installation and setup of the system.

1.3 Use and inspection

The relevant safety regulations must be followed when using the transducer system. In particular, steps must be taken to ensure that should the transducer system become defective no hazards to persons or property can result. This includes the installation of additional safety limit switches, emergency shutoff switches and maintaining the permissible ambient conditions.

1.4 Scope

This guide applies to the model BTL5-A/C/E/G...B/Z... Micropulse transducer.

An overview of the various models can be found in section 12 Versions (indicated on product label) on page 12.

Note: For special versions, which are indicated by an -SU... designation in the part number, other technical data may apply (affecting calibration, wiring, dimensions etc.).

The following patents have been granted in connection with this product:
US Patent 5 923 164
Apparatus and Method for Automatically Tuning the Gain of an Amplifier

CE The CE Mark verifies that our products meet the requirements of EC Directive 89/336/EEC (EMC Directive) and the EMC Law. Testing in our EMC Laboratory, which is accredited by DATech for Testing Electromagnetic Compatibility, has confirmed that Balluff products meet the EMC requirements of the following Generic Standards:
 EN 50081-2 (emission)
 EN 61000-6-2 (noise immunity)
 Emission tests:
 RF Emission
 EN 55011 Group 1, Class A

Noise immunity tests:
 Static electricity (ESD)
 EN 61000-4-2 Severity level 3
 Electromagnetic fields (RFI)
 EN 61000-4-3 Severity level 3
 Fast transients (Burst)
 EN 61000-4-4 Severity level 3
 Surge
 EN 61000-4-5 Severity level 2
 Line-induced noise induced by high-frequency fields
 EN 61000-4-6 Severity level 3
 Magnetic fields
 EN 61000-4-8 Severity level 4

2 Function and Characteristics

2.1 Characteristics

Micropulse transducers feature:

- Very high resolution, repeatability and linearity
- Immunity to shock, vibration, contamination and electrical noise
- An absolute output signal
- Automatic signal regulation
- 100 % adjusting range
- Removable calibration device
- 2 kHz update rate
- Error information via output signal
- Pressure rated to 600 bar
- IP 67 per IEC 60529

2.2 Function

The transducer contains a tubular waveguide enclosed by an outer stainless steel rod. A magnet attached to the moving member of the machine or to the cylinder piston is moved over the rod and its position constantly updated.

The magnet defines the measured position on the waveguide. An internally generated INIT pulse interacts with the magnetic field of the magnet to generate a magnetostrictive torsional wave in the waveguide which propagates at ultrasonic speed.

The torsional wave arriving at the end of the waveguide is absorbed in the damping zone. The wave arriving at the beginning of the waveguide creates an electrical signal in the coil surrounding the waveguide. The propagation time of the wave is used to derive the position. Depending on the version the corresponding value is output as a voltage or a current either with rising or falling characteristic. This process takes place with measuring high precision and repeatability within the stroke range defined as nominal stroke length.

At the rod end is a damping zone, within which no reliable signal is available, but which may be entered by the magnet.

The electrical connection between the transducer, the processor/ controller and the power supply is via a cable,

which depending on the version is either fixed or connected using a female connector.

Dimensions for installing the Micropulse transducer: Fig. 3-2
 Dimensions for installing the magnet: Fig. 3-4

2.3 Available stroke lengths and magnets

To provide for optimum fit in any application, a wide range of standard stroke lengths and magnets in various form factors are available. Magnets must therefore be ordered separately.

See inside front cover for available stroke lengths.

3 Installation

3.1 Mounting

When possible, use non-magnetizable material for attaching the transducer and magnet ring. Fig. 3-1.

When attaching the transducer to magnetizable materials, appropriate measures must be taken to protect against magnetic disturbances (Fig. 3-1). Note the recommended distance of the transducer and cylinder from strong, external magnetic fields.

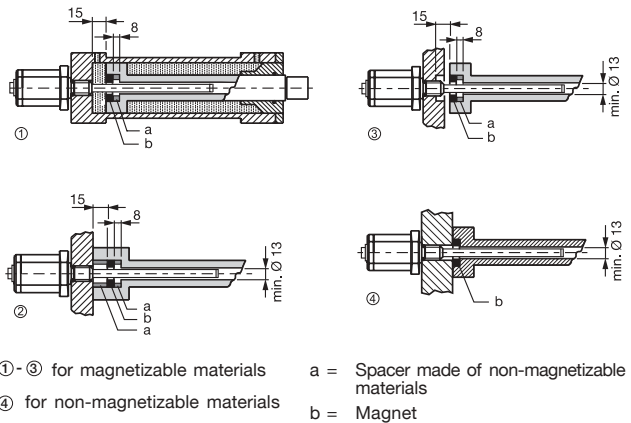

Fig. 3-1: Mounting

3 Installation (cont.)

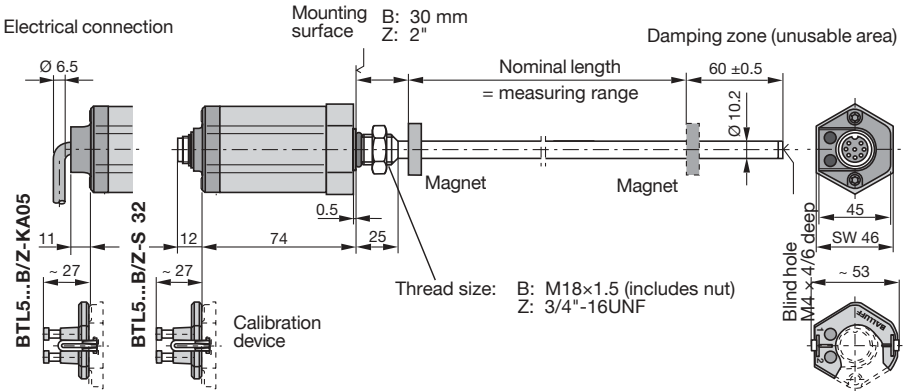

Fig. 3-2: Transducer BTL5...B/Z, Dimensions

Important Installation Notes:

The contact surface of the transducer must be completely contacted by the mounting surface. The O-ring supplied must make a perfect pressure seal, i.e. the bevel for the O-ring must be configured exactly as shown in Fig. 3-3.

To achieve secure mounting, use the proper nut for the mounting thread. When

tightening the nut, do not exceed a tightening torque of 100 Nm.

For horizontal mounting of transducer with stroke lengths greater than 500 mm, the pressure tube should be supported or attached at its end.

When installing in a hydraulic cylinder, do not allow the magnet ring to rub against the pressure tube. The bore diameter in the piston and cylinder

rod should be at least 13 mm.

When attaching the transducer to magnetizable materials, appropriate measures must be taken to protect against magnetic disturbances, Fig. 3-1.

Note the recommended distance of the transducer and cylinder from strong, external magnetic fields.

3.2 Transducer, Installation

The smallest permissible distance between magnet ring and rod mounting surface is shown in Fig. 3-2.

The transducer has either a M18x1.5 thread or a 3/4"-16UNF thread for mounting. The sealing is carried out with the O-ring supplied at the flange facing.

Threaded hole
 M18x1.5 per
 ISO 6149
 O-ring 15.4 x 2.1

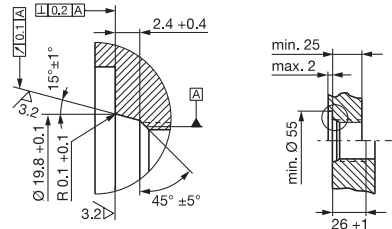

Threaded hole
 3/4"-16UNF per
 SAE J475
 O-ring 15.3 x 2.4

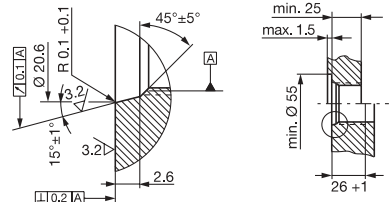

Fig. 3-3: Threaded hole for mounting the BTL with O-ring

3 Installation (cont.)

3.3 Magnets, Installation

A magnet is required for each transducer. This must be ordered separately. Fig. 3-4.

For mounting the magnet we recommend to use non-magnetizable material. Fig. 3-1.

BTL-P-1013-4R

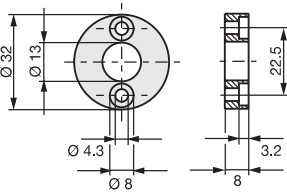

BTL-P-1013-4S

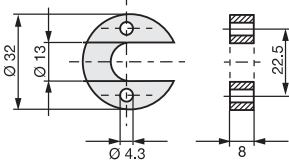

BTL-P-1012-4R

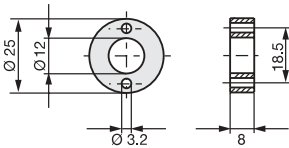

Fig. 3-4: Magnet (optional)

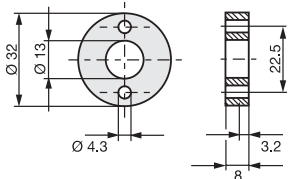

Fig 3-5: Spacer

4 Wiring

Note the following when making electrical connections:

System and control cabinet must be at the same ground potential.



To ensure the electromagnetic compatibility (EMC) which Balluff warrants with the CE Mark, the following instructions must be strictly followed.

BTL transducer and the control must be connected using shielded cable.

Shielding: Copper filament braided, 80% coverage.

The shield must be tied to the connector housing in the BKS connector (Fig. 4-3); see instructions accompanying the connector.

In the cable version the cable shield is connected to the housing in the PG fitting.

The cable shield must be grounded on the control side, i.e., connected to the protection ground.

Pin assignments can be found in Table 4-1. Connections on the controller side may vary according to the controller and configuration used.

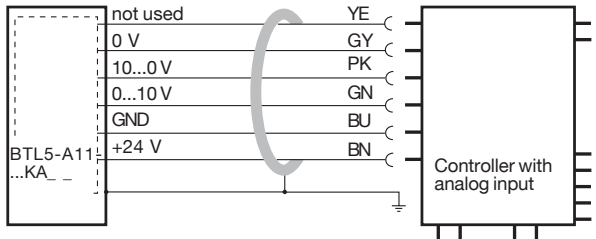

Fig. 4-1: BTL5-A11...KA__ with controller, wiring example

When routing the cable between the transducer, controller and power supply, avoid proximity to high voltage lines to prevent noise coupling. Especially critical is inductive noise caused by AC harmonics (e.g. from phase-control devices), against which the cable shield provides only limited protection.

Cable length max. 20 m; Ø 6 to 8 mm. Longer lengths may be used if construction, shielding and routing are such that external noise fields will have no effect on signal integrity.

BKS connector, view towards solder side of female BKS-S 32M-00 or BKS-S 33M-00



Fig. 4-2: Pin assignments BKS, connector type BTL

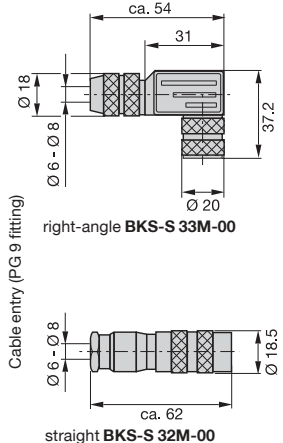
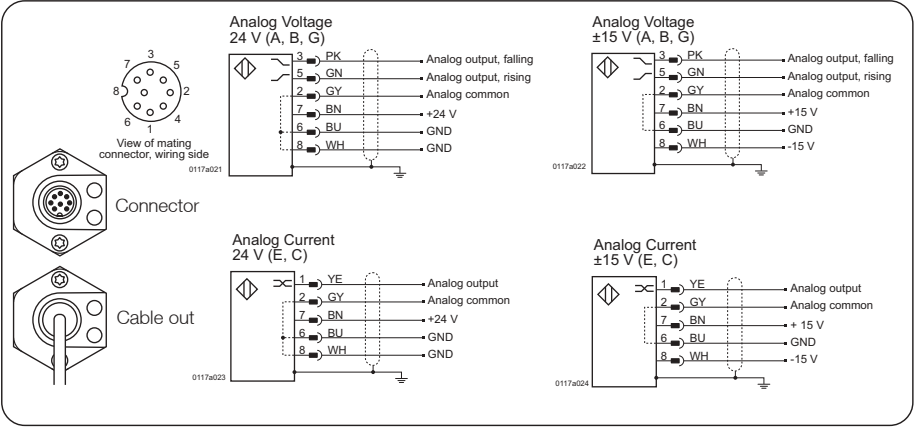

Fig. 4-3: Connector (optional)

4 Wiring (cont.)



5 Startup

5.1 Check connections

Although the connections are polarity reversal protected, components can be damaged by improper connections and overvoltage. Before you apply power, check the connections carefully.

5.2 Turning on the system

Note that the system may execute uncontrolled movements when first turned on or when the transducer is part of a closed-loop system whose parameters have not yet been set.

Therefore make sure that no hazards could result from these situations.

5.3 Check output values

After replacing or repairing a transducer, it is advisable to verify the values for the start and end position of the magnet in manual mode. If values other* than those present before the replacement or repair are found, a correction should be made.

* Transducers are subject to modification or manufacturing tolerances.

5.4 Check functionality

The functionality of the transducer system and all its associated components should be regularly checked and recorded.

5.5 Fault conditions

When there is evidence that the transducer system is not operating properly, it should be taken out of service and guarded against unauthorized use.

6 Calibration procedure

Please note:

The calibration device is to be attached to the connection end of the transducer as shown in Fig. 6-1. Connect the transducer to the controller. To monitor the calibration procedure, a display (controller or multimeter) which displays the BTL voltage or current levels is required. All settings are done with a magnet within the stroke area.

Please verify that the absolute null- and endpoints are always within the maximum and minimum possible output values (value table 7-1 on page 8).

Any desired magnet position within the factory set nominal stroke length can be assigned with a null- or endpoint. Do not however reverse the null- and endpoints.

Once the calibration procedure is concluded, the calibration device can be removed to prevent accidental changes and to store in a safe place for the next use.

The examples shown in this handbook refer to the two versions with 0 to 10 V and 4 to 20 mA outputs. For all other versions the corresponding values can be found in the value table 7-1 on page 8.

The buttons are automatically disabled after approximately 10 minutes of non-use.

Advantages:

The display will always indicate the current position value even during the calibration procedure.

The last programmed values remain stored, regardless of whether the programming mode is ended manually by pressing the buttons or automatically after 10 minutes.

6 Calibration procedure (cont.)

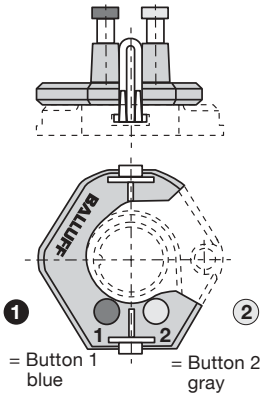

Fig. 6-1: Calibration device (shown on transducer)

6.1 Selecting calibration mode

System not running:
 Depending on the application use either Teach-in or manual adjust.

System running:
 In special situations the online setting mode may be used.

6.2 Teach-in

The factory-set null- and endpoints will be replaced by the new null- and endpoints. First move the magnet to the new null position, then to the new end position, and press the buttons to accept the corresponding value.

See Section 7: Teach-in mode

To do this, the magnet is brought alternately to the new start and end position, and the displayed values are adjusted by keystroke or pressing the buttons until the desired values are reached.

See Section 8: Manual adjust mode

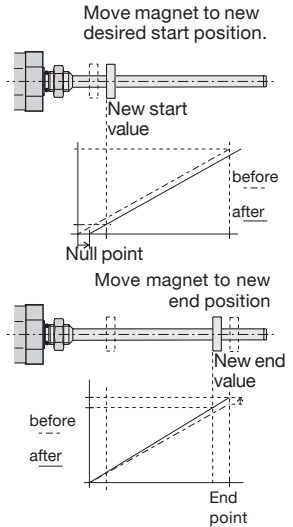

Fig. 6-4: Manual adjust procedure

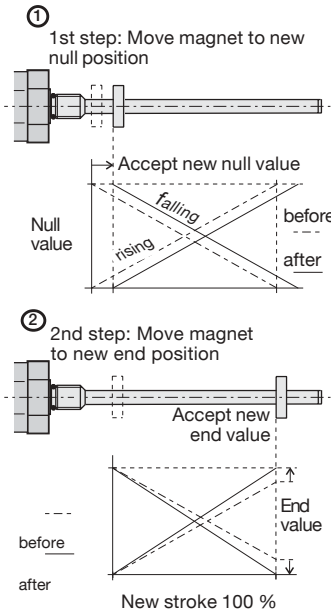
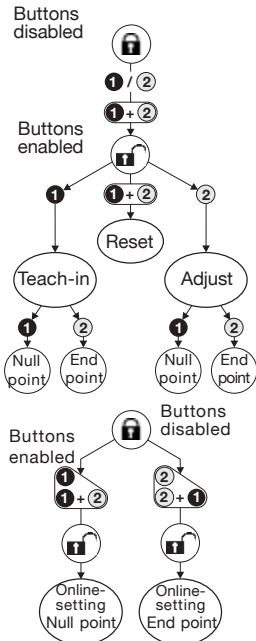

Fig. 6-3: Teach-in procedure

6.4 Reset

The reset function can be used to restore the transducer to its factory default settings.

See Section 9:s Resetting all values (Reset)

6.5 Online-setting

Setting the start and end values is done while the system is running.

See Section 10: Online setting mode

6.3 Manual adjust

This method allows you to set a new start and/or end value. This may be useful if the magnet can not be brought to the null or end point of the transducer.

7 Teach-in mode

Enable buttons:

1. Press one of the buttons for at least 3 s. Release button.
2. Within 1 s hold down buttons 1+2 simultaneously for at least 3 s. Now the Error value remains stored as the output signal.

In case of an error or a break in the activation sequence of buttons, wait for the duration of protection time of 12 s before starting the sequence anew.

Select teach-in:

Hold down button 1 for at least 2 s until the code for teach-in is displayed. Release button.

Set nullpoint:

1. Move magnet to exact desired nullpoint.
2. Hold down button 1 for at least 2 s. The new nullpoint is set.

Set end point:

3. Move magnet to exact desired end point.
4. Hold down button 2 for at least 2 s. The new end point is set.

End teach-in and disable buttons:

Hold down buttons 1+2 simultaneously for at least 6 s to end the calibration procedure until the Error value is displayed. Then press one of the buttons briefly to disable both buttons.

Check your new settings carefully before you start up the machine or system.

BTL5-A... with magnet in stroke range

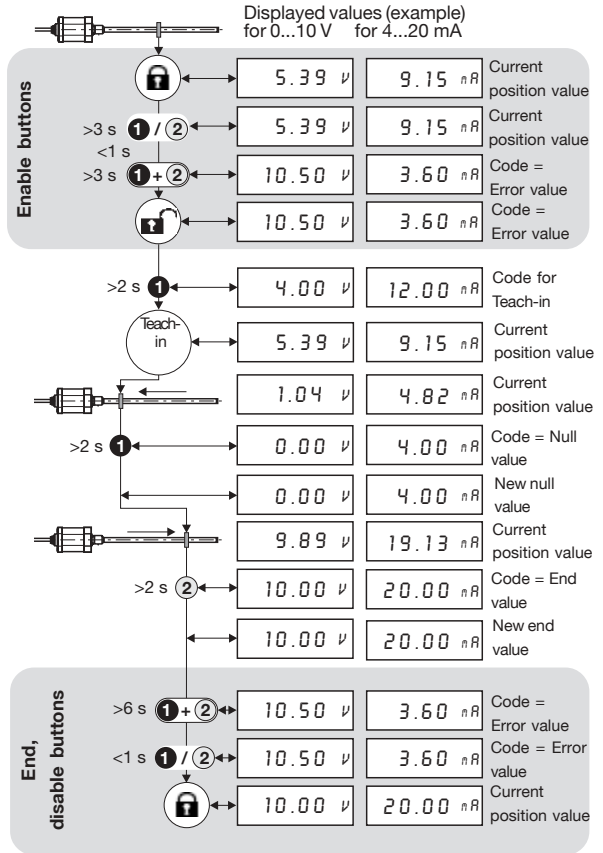

Value table for teach-in and adjusting	BTL5 version	Min. value	Null value (head end)	Code for adjusting	Code for teach-in	End value (rod end)	Max. value	Error value
rising	A (Volt)	-0.50	0	2.00	4.00	+10.00	+10.50	+10.50
	G (Volt)	-10.50	-10.00	2.00	4.00	+10.00	+10.50	+10.50
	B (Volt)	-5.25	-5.00	2.00	4.00	+5.00	+5.25	+5.25
	C (mA)	0	0	6.00	12.00	20.00	>20	>20
	E (mA)	<4	4.00	6.00	12.00	20.00	>20	<4
falling	A (Volt)	+10.50	+10.00	8.00	6.00	0	-0.50	-0.50
	G (Volt)	+10.50	+10.00	8.00	6.00	-10.00	-10.50	-10.50
	B (Volt)	+5.25	+5.00	8.00	6.00	-5.00	-5.25	-5.25
	C (mA)	>20	20.00	14.00	8.00	0	0	>20
	E (mA)	>20	20.00	14.00	8.00	4.00	<4	<4

Table 7-1: Value table for teach-in and manual adjust

8 Manual adjust mode

Enable buttons:

1. Press one of the buttons for at least 3 s. Release button.
2. Within 1 s hold down buttons 1+2 simultaneously for at least 3 s. Now the Error value remains stored as the output signal.

Select adjust:

Hold down button 2 for at least 2 s until the code for manual adjust is displayed. Release button. The current position value is displayed.

Adjust start value:

1. Move magnet to exact start position.
2. Hold down button 1 for at least 2 s.
3. Shift null point (=start value) towards flange or rod end with constant slope: Briefly pressing the buttons increases or decreases the actual value by approx. 1 mV or 2 μ A. Holding a button down for longer than 1 s increases the step size.
4. Exit calibration procedure for the start value: Press buttons 1+2 less than 2 s.

Adjust end value:

5. Move magnet to exact end position.
6. Hold down button 2 for at least 2 s.
7. Increase or reduce slope: Briefly pressing the buttons increases or decreases the actual value by approx. 1 mV or 2 μ A. Holding a button down for longer than 1 s increases the step size.
8. Exit calibration procedure for the end value: Press buttons 1+2 less than 2 s.

Additional notes:

Setting the end value (i.e. the slope) and the start value can mutually affect each other depending on the stroke position. You will need to repeat steps 1 to 8 over until the start and end values agree with their respective desired values.

End adjustment, disable buttons:

Hold down buttons 1+2 simultaneously for at least 6 s to end the calibration procedure until the Error value is displayed. Then press one of the buttons briefly (<1 s) to disable both buttons.

Check your settings carefully before starting up the system.

BTL5-A... with magnet in stroke range

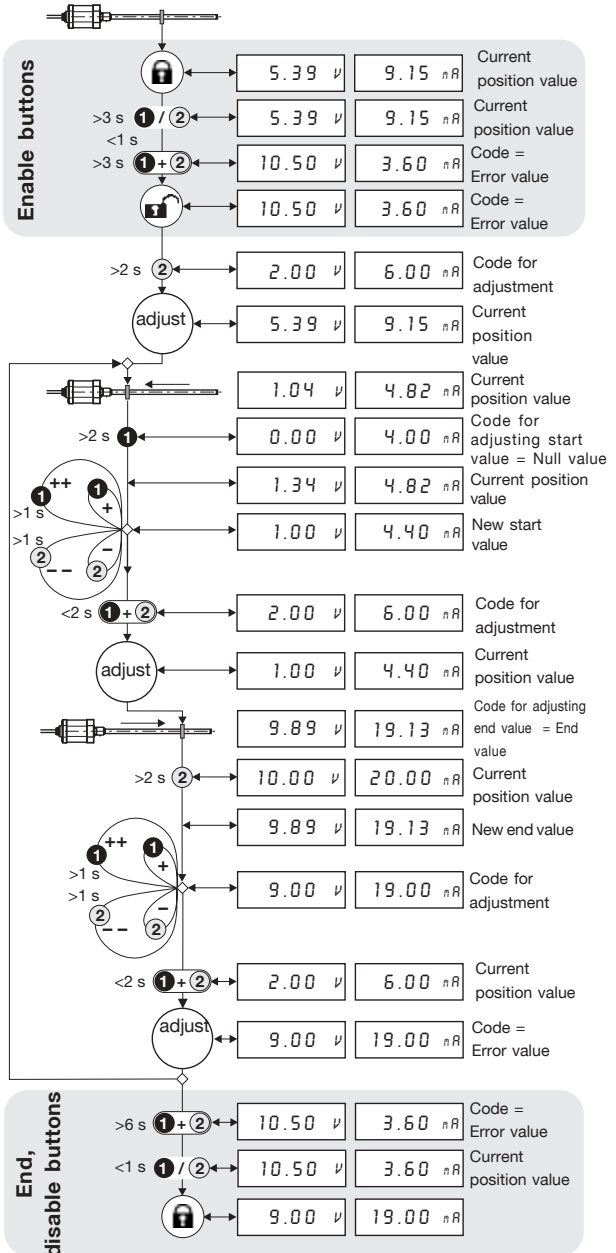

9 Resetting all values (Reset)

If an existing configuration needs to be deleted, all values can be restored to the original factory settings (Reset).

Activate buttons:

1. Press one of the buttons for at least 3 s. Release button.
2. Within 1 s hold down buttons 1+2 simultaneously for at least 3 s. Now the Error value remains stored as the output signal.

If an error occurs or there is an interruption while activating a button, please wait for an additional 12 s before starting over.

Perform reset:

3. Hold down both buttons for at least 6 s. The Null value is displayed, and the reset has taken place.
4. Release buttons. The current position value is displayed and the buttons are again deactivated.

The transducer is ready for new calibration.

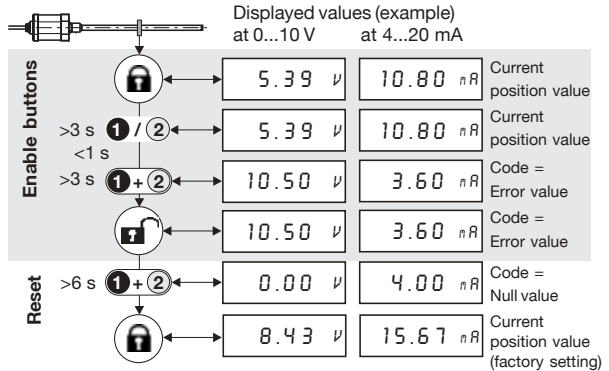

10 Online-setting mode

The BTL output signal at a particular magnet position is set to the desired value which is then stored by the controller as a start or end value without having to power down the entire system. For this reason the safety advisory at right should be especially noted.

Setting start value online:

1. Position system so that the magnet ring is located at the start position.
2. Activate buttons:
Hold button 1 down for at least 3 s and then - without releasing button 1 - hold both buttons down for at least 3 s.
3. Setting the value:
Briefly pressing the buttons increases or decreases the actual value by approx. 1 mV or 2 μ A. Holding a button down for longer than 1 s increases the step size.
4. Once the adjustment range or the desired start value is reached, the setup mode is automatically exited if no button is pressed for at least 15 s. The buttons are again disabled. Another adjustment procedure can be carried out.

Setting end value online:

1. Position system so that the magnet ring is located at the end position.
2. Activate buttons:
Hold button 2 down for at least 3 s and then - without releasing button 2 - hold both buttons down for at least 3 s.
3. Setting the value:
Briefly pressing the buttons increases or decreases the actual value by approx. 1 mV or 2 μ A. Holding a button down for longer than 1 s increases the step size.
4. Once the adjustment range or the desired end value is reached, the setup mode is automatically exited if no button is pressed for at least 15 s. The buttons are again disabled. Another adjustment procedure can be carried out.

CAUTION!



In this procedure the machine with the BTL system remains operational, i.e., any change in the BTL output signal may cause the machine to respond.

Be sure that this response will not result in any risk to persons or equipment!

Maximum adjusting range for each adjustment procedure:

Start value = max. $\pm 12.5\%$ of actual stroke,
 End value = max. $\pm 12.5\%$ of actual output value.

Note: Between each adjustment procedure - also between setting of start and end value - has to be exited by waiting 15 s (time out) until the next adjustment can be carried out.

When the desired value cannot be reached within the first adjustment procedure because the adjustment range of $\pm 12.5\%$ is exceeded, another adjustment can be carried out after 15 s. This can be repeated until the desired value is achieved.

BTL5-... with magnet at end of stroke

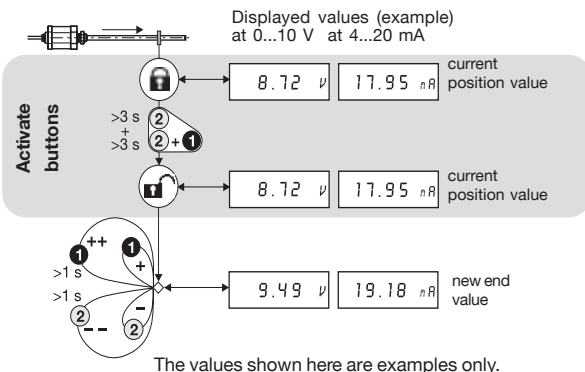

BTL5-... with magnet in start position

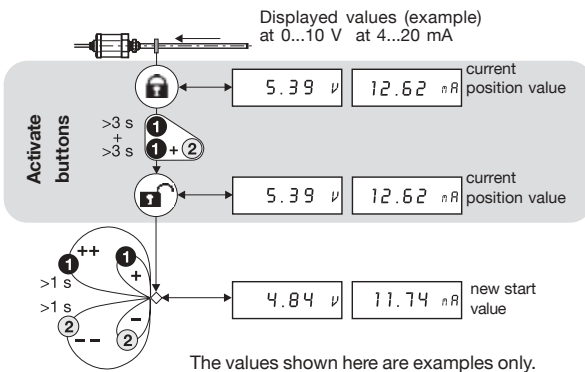

BTL5-A/C/E/G -M -B/Z-S32/KA
Micropulse Linear Position Transducer
Analog Output-Rod Style



11 Technical Data

Typical values at DC 24 V and 25 °C. Ready for operation at once, full accuracy after warm-up. With magnet: BTL-P-1013-4R, BTL-P-1013-4S or BTL-P-1012-4R:

Resolution, + Hysteresis = Repeatability		
Voltage	0.3 mV	
Current	0.6 µA	
Minimum	0.05 mm	
Sampling rate f _{Standard}	= 2 kHz	
Non-linearity		
Nom. length ≤ 500 mm	> 500 mm	
in µm	±100	±0.02 % FS

Temperature coefficient
 Voltage output:
 [150 µV/K + (5 ppm/K · P · V/NL)] · ΔT
 Current output:
 [0,6 µA/K + (10 ppm/K · P · I/NL)] · ΔT

V = output voltage range in [V]
 I = output current range in [mA]
 NL = nominal length in [mm]
 ΔT = temperature coefficient in [K]
 P = magnet position in [mm]

- **Shock** 100 g/6 ms per IEC 60068-2-27¹
- **Continuous shock** 100 g/2 ms per IEC 60068-2-29¹
- **Vibration** 12 g, 10 to 2000 Hz per IEC 60068-2-6¹ (take care to avoid inherent resonances of protective tube)
- **Pressure** up to 600 bar when installed in a hydraulic cylinder

¹ Individual specifications as per Balluff factory standard

11.1 Dimensions, weights, ambient conditions

- **Nominal length** ≤ 4000 mm
- **Dimensions** Fig. 3-2
- **Weight** ca. 2 kg/m
- **Housing** anodized aluminum
- **Pressure tube** stainless steel 1.4571
- **Diameter** 10.2 mm
- **Wall thickness** 2 mm
- **E-modulus** ca. 200 kN/mm²
- **Mounting thread** M18×1.5 or 3/4"-16UNF
- **Operating temp.** -40 °C to +85 °C
- **Humidity** < 90 %, non-condensing
- **Protection rating** per IEC 60529 IP 67 with connector attached

11.2 Supply voltage (external)

Regulated supply voltage
 BTL5-1... DC 20 to 28 V
 Ripple ≤ 0.5 V_{pp}
 BTL5-2... DC ±14.7 to ±15.3 V
 Current draw ≤ 150 mA
 Inrush ≤ 3 A/0.5 ms
 Polarity reversal protection built-in
 Overvoltage protection
 Transzorb diodes
 Electric strength 500 V
 GND to housing

11.3 Outputs

BTL5-A...	
Output voltage	0...10/10...0 V
Load current	≤ 5 mA
Ripple	≤ 5 mV
BTL5-G...	
Output voltage	-10...10/10... -10 V
Load current	≤ 5 mA
Ripple	≤ 5 mV
BTL5-C...	
Output current	0...20/20...0 mA
Load resistance	≤ 500 Ohm
BTL5-E...	
Output current	4...20/20...4 mA
Load resistance	≤ 500 Ohm

11.4 Connection to controller

Analog interface:
 With S32 connector for shielded cable (max length, see "Wiring"), diameter 6 to 8 mm, or with integral cable (5m long)

11.5 Included in shipment

Transducer	Fig. 3-2
Calibration device	Fig. 6-1

11.6 Magnets (order separately)

Magnets BTL-P-1013-4R, BTL-P-1013-4S, BTL-P-1012-4R

Dimensions	Fig. 3-4
Weight	approx. 10 g
Housing	anodized aluminum
Operating temp.	-40 °C to +85 °C

Magnets BTL5-P-4500-1

(Electromagnet)	
Weight	approx. 90 g
Housing	plastic
Operating temp.	-40 °C to +60 °C

11.7 Accessories (optional)

Connectors	Fig. 4-3
------------	----------

12 Versions (indicated on product label)

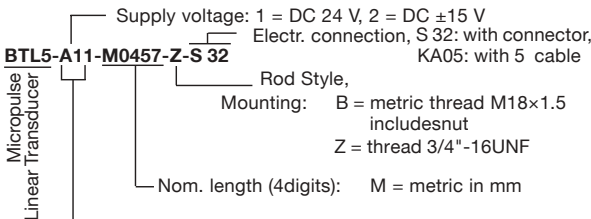

Analog interface:

Voltage output A ₁	= 10 ... 0 V and 0 ... 10 V
G ₁	= 10 ... -10 V and -10 ... 10 V
Current output C ₀	= 0 ... 20 mA
C ₇	= 20 ... 0 mA
E ₀	= 4 ... 20 mA
E ₇	= 20 ... 4 mA

7 Magnet and Control Arm Diagram References

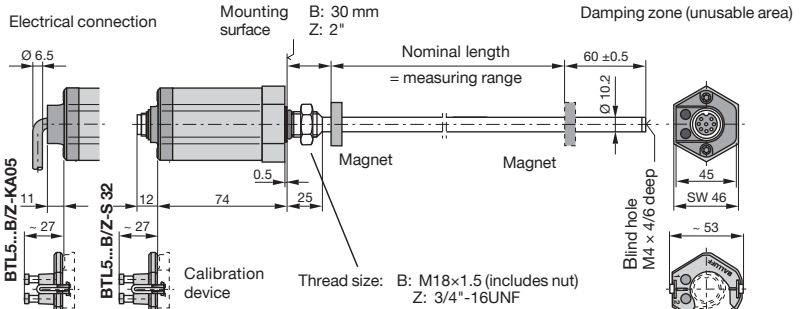
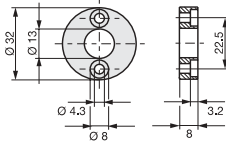
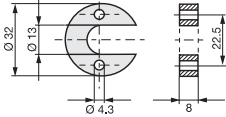

Fig. 3-2: Transducer BTL5...B/Z, Dimensions

BTL-P-1013-4R



BTL-P-1013-4S



BTL-P-1012-4R

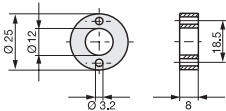
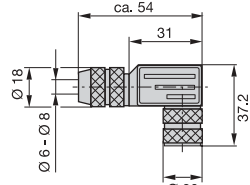
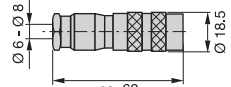

Fig. 3-4: Magnet (optional)



Cable entry (PG 9 fitting)

right-angle **BKS-S 33M-00**
 No. 99-5672-78-08
 (Binder part no.)



straight **BKS-S 32M-00**
 No. 99-5672-19-08
 (Binder part no.)

Fig. 4-3: Connector (optional)

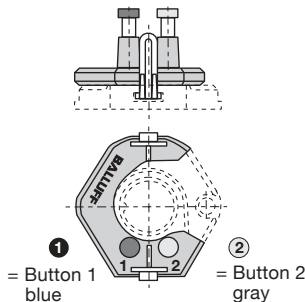

Fig. 6-1: Calibration device
 (shown on transducer)

Complete Product Range



*Inductive
Sensors*



*Photoelectric
Sensors*



*Micropulse™
Transducers*

Germany

Global Headquarters

Balluff GmbH
Schurwaldstraße 9
73765 Neuhausen a.d.F.
Telefon: +49 (0)71 58/1 73-0
Telefax: +49 (0)71 58/50 10
Hotline: +49 (0)71 58/1 73-370
Web: www.balluff.de
E-mail: balluff@balluff.de

USA

North American Headquarters

Balluff Inc.
8125 Holton Drive
Florence, KY 41042
Phone: (859) 727-2200
Toll-free: 1-800-543-8390
Fax: (859) 727-4823
Web: www.balluff.com
E-Mail: balluff@balluff.com

Canada

Balluff Canada, Inc.
2840 Argentia Road, Unit #2
Mississauga, Ontario L5N 8G4
Phone: (905) 816-1494
Toll-free: 1-800-927-9654
Fax: (905) 816-1411
Web: www.balluff.ca
E-mail: balluff.canada@balluff.ca

Mexico

Balluff de Mexico S.A. de C.V
Fray Pedro de Gante 25 P.B.
Col. Cimatarío
Queretaro, QRO 76030
Phone: (+52 442) 212-4882,
224-3583, 224-3171
Fax: (+52 442) 214-0536
E-mail: balluff.mexico@balluff.com



*Capacitive
Sensors*



*Magnetic Field
Sensors*



*Electromechanical
Sensors*



*Identification
Systems*



*Connectors &
Accessories*